



ZM223

Avery Weigh-Tronix

Specifications

This high-performance, multi-functional indicator gives you the required flexibility to suit most industrial applications. It is suitable for office areas, industrial facilities, food production, and indoor/outdoor environments, as well as dusty, wet, or heavy washdown environments. The ZM223 provides an easy way to analyze, store, display and transmit data across a wide range of technology methods and comes standard with a wide range of configurable/programmable software applications to meet your needs.

General

Operating Applications	Configurable and programmable apps stored on a micro-SD card: General Weighing, Accumulation, Counting, Check-Count, Checkweighing, % Weight Gain, Grading, Filling, Batching, Animal Hold, Peak Hold, Remote Display, Truck In-Out (See App functionality for more info)
Remote Assist™ Mobile App	Compatible with Avery Weigh-Tronix Remote Assist™ Mobile App. Provides an easy method to quickly enter valuable alphanumeric data into the indicator which can be used for printing or for viewing weight data from a distance through to fast line setup and other data retrieval.
Unit of Measure	Up to three configurable: lb, lb/oz, oz, kg, g, one custom
Capacity Selections	9,999,999 with decimal located zero to five places. Display supports up to six decimal places, if software supports that many.
Incremental Selections	Multiples and sub-multiples of 1, 2, 5
Programmable Selections	Zero range, motion detection, automatic zero tracking, five-point linearization
Time and Date	Battery backed up time/date/year (12-hour AM/PM or 24-hour format)
Calibration	Two to ten points stored
Analog to Digital Measurement Rate	Rate 80Hz
Internal Resolution Analog	53,687,100 counts per mV/V per second
Internal Resolution Digital	One billion internal counts per second when linked to the BSQ Digital Base
Digital Filtering Harmonizer	Harmonizer filtering with configurable constant, average and threshold
Self-Diagnostics	Display, keys, inputs, outputs, serial port, Scale A to D, USB port and option cards
Dynamic Weighing	Minimum nominal weigh time 100 milliseconds, recommended minimum 300 milliseconds

User Interface

Keypad	19 robust, flat, easy-to-clean keys and chemical resistant keypad with audio beep feedback
Operational Keys	Tare, Select, Zero, Print, Units, F1, Enter, 0-9, Decimal, Clear
RPN Function	Provides a secondary function for each key via configuration. Configurable Keys: Select, Print, Units, F1, and Enter
Status Annunciators	Center of Zero, Motion, Gross, Net, Tare, Preset Tare, Print, Battery Status, Scale Numbers 1, 2, Over/Under/Accept Bar Graph, Bluetooth, Ethernet Connection, Weight Bands 1,2,3, lb, kg, g, three Custom Annunciators
Display	Sunlight readable transfective HTN display, seven fourteen-segment, 1.5" (38 mm) high alphanumeric characters, illuminated with color changing backlight (Green, Red, Orange and Yellow)
Display Rate Selectable	(1, 2, 5, 10) times per second

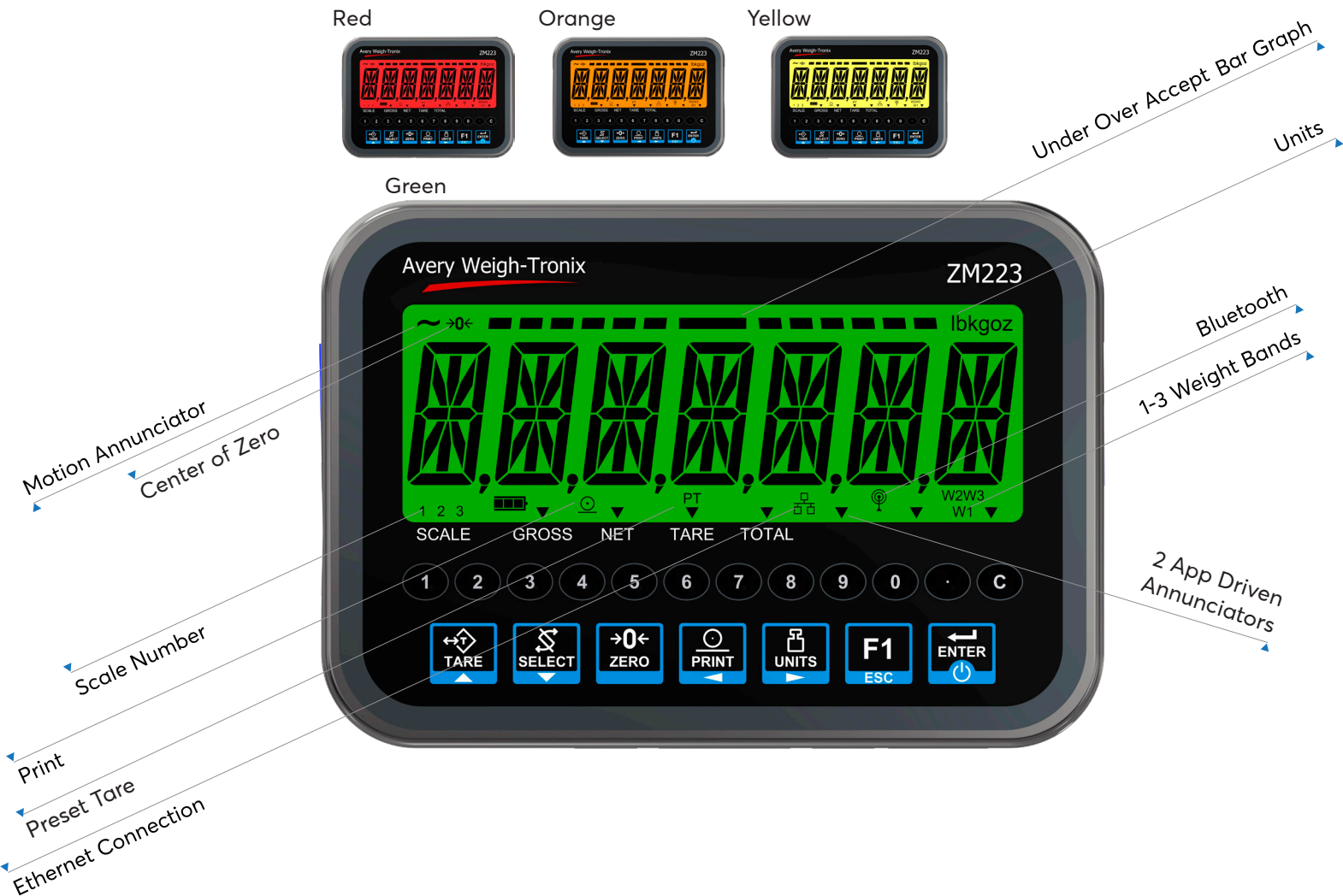

Electrical

Power Requirements	Line voltage: 90-264 VAC (110-240 VAC nominal), frequency 50 or 60Hz, 12 to 24VDC Power consumption: estimated at 200mA at 12VDC for one 350-ohm weight sensor and 250mA at 12VDC for eight 350-ohm weight sensors	Excitation	5VDC, short circuit protected. Supports up to eight 350-ohm weight sensors Four or six conductors with sense leads Detachable plug connectors
Max Current	0.5A or 1A using an external 12VDC power	Analog Signal Input Range	-1 mV/V to 5 mV/V
Weight Ranges	Single range: up to 10,000d Legal-for-Trade Multi range (MR): 2 to 3 ranges Multi interval (MI): 2 to 3 ranges	Analog Signal Sensitivity	0.1 μ V/V/divisions minimum 0.5 μ V/V/divisions recommended
Number of Bases	Up to two bases: one analog base and one BSQ Digital Bench Base or two BSQ Digital Bench Bases	Analog Signal Protection	RFI, EMI and ESD protection

Physical Housing

Enclosures

Stainless steel: 304 brushed stainless steel (IP69K certified) with water and dust resistant, breathable, vented gland and tilt stand with provisions for desk, wall and column mounting

Shipping Weight & Dimensions

8.4 lb (3 kg)
14" x 12" x 6.5" (356 mm x 305 mm x 165 mm)

Operating Temperature

14° F to 104° F / -10° C to 40° C
(Compliance with legal-for-trade requirements)

-4° F to 140° F / -20° C to 60° C
(industrial)

10 to 90% humidity noncondensing

Dimensions

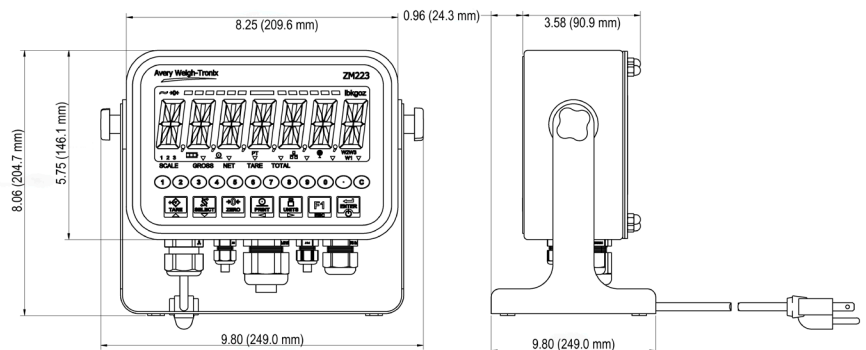

Approvals

Agencies Single-interval, multi-range or multi-interval:
NTEP 10,000d (24-075), Measurement Canada 10,000d (AM-6261C), EU 10,000d (0200-NAWI-19072), OIML R76 10,000d (pending), India 10,000d (I-21/177/2025-W&M), CE, NOM, IFT (pending), NSF, UL/C-UL, IP69K

Input-outputs/Data Storage

Remote Inputs	Up to six logic level inputs for Zero, Print, Tare, Units, F1, and more Configurable apps: Mostly use three inputs Programmable apps: Can be programmed to be either inputs or outputs up to a max of six	Bluetooth®	BLE used to connect to Remote Assist™ Mobile IOS, Android, Windows App
Standard Outputs	Up to six outputs Configurable apps: Mostly use three inputs, three outputs Programmable apps: Can be programmed to inputs or outputs	Micro-SD Slot	Compatible with micro-SD cards up to 32GB, read individual files up to 4GB
Serial Ports	Two serial Comm ports: internally wired <ul style="list-style-type: none"> • Comm 1 RS232 full duplex • Comm 2 RS232 full duplex • Both RS232 comm ports can also be used to drive a B5Q high-precision digital bench base Utilize via all standard protocols: SMA, Broadcast, ENQ, NCI, etc. Fully programmable via LUA.	Micro-SD Card Usage	Supplied with 16GB micro-SD cards as standard Micro-SD card also holds all our configurable Avery Weigh-Tronix apps that can be selected to run based on each customers needs <ul style="list-style-type: none"> • Scale profile backup • PLU database storage backup area • Alibi memory data storage backup area • ZM223 app library retrieval area • Transaction data storage
USB Host	Internal USB A connection for USB Printer, USB Memory, USB Scanner, USB Keyboard, and optional external washdown USB connector	Programming Language	Lua programmable and fully configurable. Comes standard with a library of applications stored on the internal micro-SD card.
Ethernet	Embedded Web Server <ul style="list-style-type: none"> • Internal web server for device configuration and monitoring • Supports HTTP and HTTPS (secure and non-secure access) Industrial Ethernet Protocols <ul style="list-style-type: none"> • EtherNet/IP (EIP) • Modbus TCP API & Cloud Connectivity <ul style="list-style-type: none"> • HTTPS/RESTful API for modern application and cloud integration • MQTT for lightweight, publish/subscribe messaging and IIoT applications Socket Communication <ul style="list-style-type: none"> • TCP and UDP socket support • Enables custom client/server and peer-to-peer communication 	Data Drive Storage	Configurable (flash memory, USB storage memory, micro-SD card, or external to a PC or cloud server)
		Alibi/Archiving Memory	100,000 transactions
		Optional	Holds one of the following option cards <ul style="list-style-type: none"> • Analog output card • STVS extreme lightning surge protection ideal for use with outdoor platforms or weighbridges Can be fitted with one of these external glands <ul style="list-style-type: none"> • USB A watertight gland • Ethernet watertight gland



More online

- Technical specifications
- User manuals
- News and information

Avery Weigh-Tronix

www.averyweigh-tronix.com

Avery Weigh-Tronix is an ITW company