



## BENEFITS

**Smart diagnostics** – The active alarm messaging feature monitors the system to identify a fault and provides a faster turnaround for service. With the added 'Ghosting' feature, the system can be kept up and running, even when one sensor fails (non-trade approved mode only).

**Faster installation, simplified calibration** – Each **ZT Digital Load Cell** is factory calibrated and supplied with ready-assembled load buttons resulting in quick and simple installation. The Amphenol LTW® X-Lok connectors make the interconnection of the **ZT Digital Load Cells** a faster, flexible and error-free operation.

**Built to last** – The thick hermetic stainless steel wall protects the internal elements while the two-stage TVS help to neutralize the effects of lightning. The industry leading data cables have a SST overbraid and dual-screen system for maximum abrasion resistance and EMI immunity.

**Enhanced weighing applications** – 6 million internal divisions and the smart communication protocol assure precision, reliability and system customization to meet any weighing application needs, including: multiscale, load balancing and anti-fraud measures.

**Intelligent system management** – The **ZT Digital Load Cell** are directly interconnected to a secure digital backbone network. This solution allows the Avery Weigh-Tronix ZM605/ZM615 Indicators to manage up to 32 cells over two separate networks without the need for a junction box or termination plug.

# ZT DIGITAL LOAD CELL

Smart - Rugged - Accurate

## Technical Specification

### DESCRIPTION

The **ZT Digital Load Cell** is a high accuracy, hermetically sealed to IP68/69K canister cell, which connects to a smart network without the need for a junction box.

Each **ZT Digital Load Cell** is factory tested and calibrated to supply outstanding weighing performance even in the most extreme operating conditions.

### AVAILABLE CAPACITY

- › 66,000 lbs
- NTEP approved for accuracy class III L 10,000d
- OIML R60 approved for accuracy class C6

### INDUSTRY APPLICATIONS

Due to its industry standard height and conversion kits, the **ZT Digital Load Cell** is used in a wide variety of heavy-capacity applications.

The **ZT Digital Load Cell** technology helps you to maximize performance and profitability while meeting the strictest legislative requirements.

### SPECIAL FEATURES

- › IP68 designed cell
- › IP69K sealed cell-cable entry (certified)
- › Amphenol LTW® quick push-lock connections
- › Aircraft-quality alloy stainless steel construction
- › Factory calibrated and pre-linearized
- › Continuous self-diagnostics
- › No junction box or termination connector required
- › Integral lightning protection (Class 4 certified)
- › Anti-fraud digital bus protocol
- › Configurable for multiscale systems
- › Pre-assembled, anti-rotation load buttons

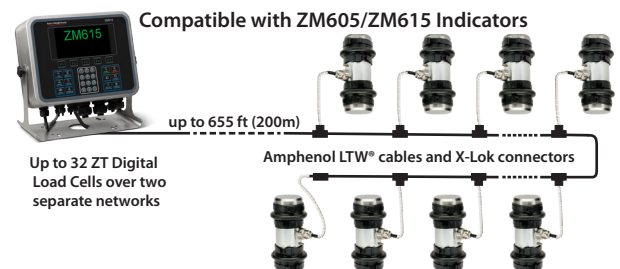

\*Maximum length of the home run cable is subject to the number of cells connected

# ZT DIGITAL LOAD CELL *Technical Specification*

## SPECIFICATIONS

### GENERAL

Trade Name	ZT Digital Load Cell
Model Name	T301X
Load Cell Type	Column compression, digital weight processor
Rated Capacity (R.C.)	66,000 lb
Sensitivity	6,000,000 divisions (internal @ rated capacity)
Communication	Linear Bus Network - RS485 multi drop protocol with anti-fraud and self-diagnostic features
Communication Rate	115.2K bps
System Update Rate	50 Hz (automatically adjusted)
Asset Management	Up to 32 logically addressed and serial number traceable ZT Digital Load Cells. Two separate networks can each support maximum of 16 load cells.

### WEIGHING PERFORMANCE

Temperature Range	<i>Compensated (NTEP/OIML): 14°F to 104°F / -10°C to +40 °C</i> <i>Operating: -40°F to +149°F / -40 °C to +65 °C</i> <i>Safe Storage: -58°F to +185°F / -50 °C to +85 °C</i>
Warm-Up Time	15 minutes
Tilt Angle	Up to ±3° from axis of gravity, top and bottom rocker-column suspensions
Accuracy Class, nmax	NTEP Class III L, 10,000d / OIML R60, C6, 6000d
Non-Repeatability	<±50 ppm @ rated capacity
Zero Return (+30 min)	<±80 ppm @ rated capacity
Creep (10 s to 30 min)	<±120 ppm @ rated capacity
Temperature Effect (range 14°F to 104°F / -10°C to +40°C)	<i>On Zero Balance: &lt;±15 ppm @ rated capacity/°C</i> <i>On Span: &lt;±6 ppm @ rated capacity/°C</i> <i>Metrology Combined Error: &lt;150 ppm @ rated capacity</i>

### DIAGNOSTICS

Load Cell	Communication status, overload counter and peak weight, temperature, cell live weight
Error Log	Scale over/under load, ZT Cell overload, Scale-ZT Cell communication status, Ghosting activation (if enabled)
Notification Systems	On-screen alerts and event logger, web and email (programmable)
Corrective Measures	Weighbridge Balance Check, Ghosting feature (for non-trade approved mode only)

### METROLOGICAL APPROVALS

Standard	NTEP Certificate 21-086 / OIML Certificate No. R60/2000-A-GB1-21.01
Additional Marking	CH (Hermetic seal)
min Dead Load	0 lb / 0 kg

### ELECTRICAL

Supply Voltage	±12 VDC, internally regulated
A/D Conversion	Four pairs of load-measuring gauges to a 24-bit sigma-delta ( $\Sigma\Delta$ ) analog-to-digital modulator
EMC and Surge Immunity	Certified to IEC 61000-4-5, Level 4: for severe environments (test reports on file)
Lightning Protection	Integral (all lines), two-stage surge suppressors
Insulation R (strain gauge circuit)	≥5000 MΩ at 50 VDC
Cell-Cable Entry	Sealed by Glass-to-Metal header, hermetic to IP69K with integral 3.2 ft (1m) long Amphenol LTW® polyurethane jacketed data cable with SST overbraiding: 0.26 in (6.7mm), 4 core+drain, pair twisted with dual metal screen system and X-Lok T-connector (included)
Connectors	Amphenol LTW® X-Lok connectors, IP68 (3.28 ft (1m) - 7 days tested. Conform to EIA364-09/21C/23C/20D: Durability, Insulation/Contact Resistance and withstanding voltage test
Cable, Cell to Cell	13.1 ft or 29.5 ft (4m or 9m) long, extendable Amphenol LTW® polyurethane jacketed data cable with SST overbraiding: 0.26" (6.7mm), 4 core+drain, pair twisted with dual metal screen system and X-Lok connectors.
Cable, Home Run	49.2 ft (15m) long, extendable Amphenol LTW® polyurethane jacketed data cable with SST overbraiding: 0.26" (6.7mm), 4 core+drain, pair twisted with dual metal screen system, X-Lok connector and stripped ends.

## MECHANICAL

<b>Material, Cell</b>	Enclosure: 0.09" (2.35mm) thick, 304 2B finish stainless steel outer wall Spring Element: Aircraft quality, 15-5 and 17-4 PH stainless steel (magnetic) Load Buttons: EN24 high strength steel alloy, hardened and tempered
<b>Type of Protection</b>	Cell Casing: Hermetic (submersible) Connectors: Hermetic, flammability (UL94V-0), UV exposure (UL-f1) and salt spray corrosion (EIA364-26B)
<b>IP Rating (IEC 60529)</b>	Cell and Connectors: IP68, 3.2 ft (1m) - 7 days submersion (tested) Cell-Cable Entry: IP69K, hermetic seal (test reports on file)
<b>Load Limit, Compression</b>	Safe: 150% @ rated capacity Ultimate: 230% @ rated capacity Fatigue Life @ rated capacity: 1,000,000 cycles
<b>Anti-Rotation Measures</b>	External, pin locking system to secure the low-friction and grease-sealed load buttons Integral, double-camber load bearing surfaces with specially designed end radiuses Top and bottom rubber gaiter bellows as standard.

## PACKAGING

<b>Shipping Weight</b>	12.1 lb / 5.5 kg Includes load buttons and Amphenol LTW® X-Lok T-connector
<b>Packaging Dimension (H x W x L)</b>	9.84 in x 9.84 in x 7.48 in / 250 mm x 250 mm x 190 mm

## DIMENSIONS

**ZT Digital Load Cell** with pre-assembled load buttons and integral Amphenol LTW® data cable entry.  
Amphenol LTW® X-Lok connectors not shown.

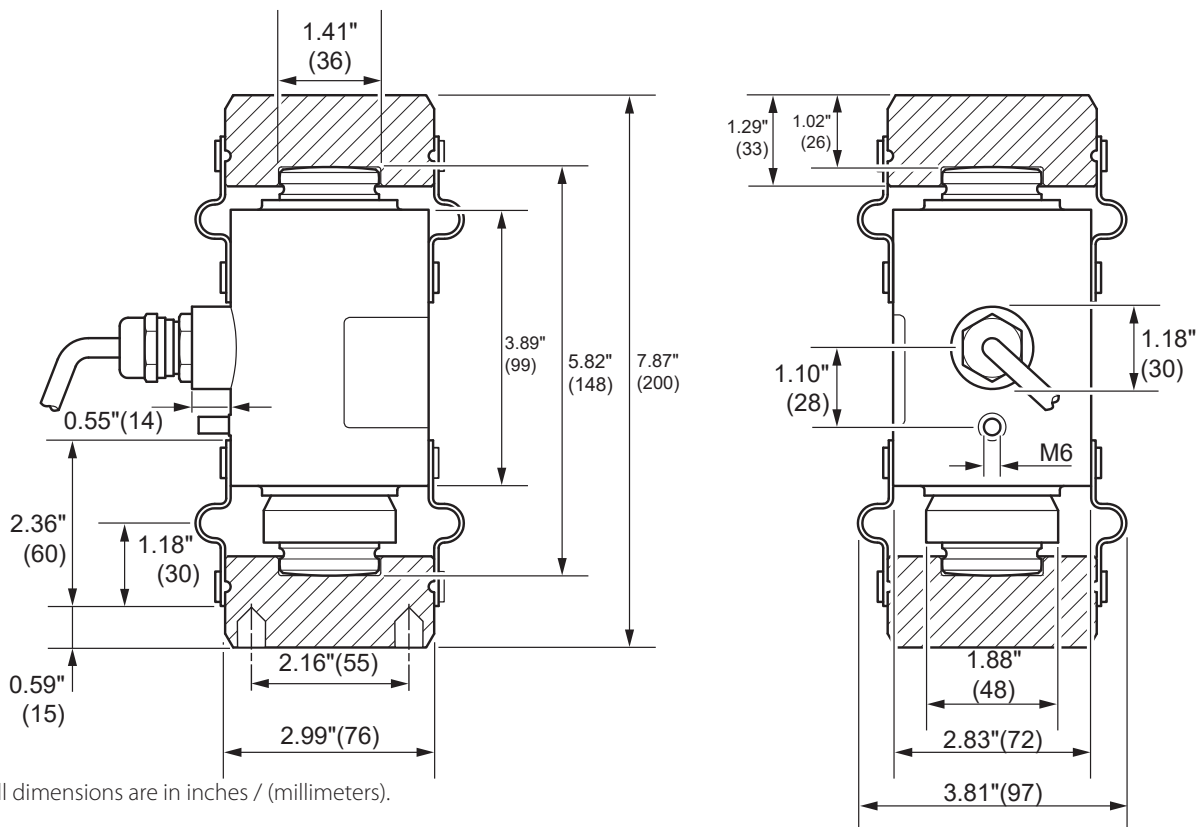

# Avery Weigh-Tronix



[www.averyweigh-tronix.com](http://www.averyweigh-tronix.com)

**Avery Weigh-Tronix is an ITW company**

Avery Weigh-Tronix is a trademark of the Illinois Tool Works group of companies whose ultimate parent company is Illinois Tool Works Inc ("Illinois Tool Works"). Copyright © 2024 Illinois Tool Works. All rights reserved. This publication is issued to provide outline information only and may not be regarded as a representation relating to the products or services concerned. This publication was correct at the time of going to print, however Avery Weigh-Tronix reserves the right to alter without notice the specification, design, price or conditions of supply of any product or service at any time.

ZTDigitalLoadCell\_spec\_100151.indd  
V1 AWT35-100151