

TRUCK SCALES



Avery Weigh-Tronix

TS

Legendary reliability and precision with the exclusive Weigh Bar® and rugged truck scale design backed by an industry-leading warranty.

Truck Scales

A Rugged Lineup

A wide variety of reliable, rugged and precise truck scales to suit any vehicle or location

Avery Weigh-Tronix

Avery Weigh-Tronix offers the best selection, features, options and value in the industry, backed by an exceptional warranty.

BridgeMont®

Long-lasting performance for heavy to moderate traffic and axle loads

The versatile BridgeMont series offers an unbeatable combination of structural integrity and cost effective ownership. With many sizes and capacities to choose from, BridgeMont fits virtually any application.

- › **Fully assembled** – Scales arrive on-site fully assembled and are easily installed in a pit, or above ground on a slab or piers. Available with a steel or concrete deck surface.
- › **Low profile** – Features a low 14" profile that saves real estate and construction costs by using a shorter approach area. Higher profile for additional clearance is easily accomplished with affordable base plate options.
- › **Standard to custom** – A wide range of standard lengths and widths or custom built to customer specifications.

BridgeMont Heavy Duty

The BridgeMont Heavy Duty is a rugged scale that can easily handle heavy traffic and axle loads beyond legal highway limits. It is also available as a portable unit. The Low-Pro 8 version of the BridgeMont Heavy Duty comes in special lengths with an extra-low profile down to 11" to serve as a replacement for other brands of scales on existing foundations.

BridgeMont Standard Duty

The BridgeMont Standard Duty provides an economical solution for applications with moderate traffic and axle loads up to highway limits. It utilizes the same sandwich steel construction and Weigh Bars as the heavier models for outstanding strength and reliability.





SteelBridge XT

Long-lasting performance for extreme traffic and axle loads

SteelBridge XT is a true heavyweight in the industry. Engineered to thrive on heavy, frequent, day-to-day use, the XT is often used in aggregate, logging, and recycling operations as well as for high traffic, over-the-road weighing.

The extra rugged design and construction means structural integrity will be maintained, even after many years of heavy use. With a 15-year truck scale warranty, you can be sure SteelBridge XT will still be in operation long after a competitor's scale has worn out.

- › **Fully assembled** – Scales arrive on-site fully assembled and are easily installed in a pit, or above ground on a slab or piers. Available with a steel or concrete deck surface.
- › **Low profile** – SteelBridge XT features a low 14" profile that saves real estate and construction costs by using a shorter approach area. Higher profile for additional clearance is easily accomplished with affordable base plate options.
- › **Standard to custom** – A wide range of standard lengths and widths or built to customer specifications. Also available as a portable unit.



TS

Multi-Platform Scale

One-stop, legal-for-trade axle weighing

Choose any combination of BridgeMont or SteelBridge XT scale platforms to create a legal-for-trade, one-stop axle weighing system.

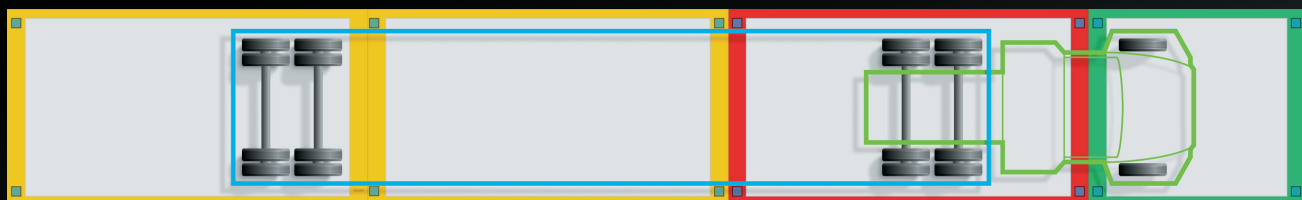
- › **Fast axle weighing** – Individual scale platforms trim minutes off traditional axle weighing methods, substantially increasing productivity.



Trailer axle scale

Drive axle scale

Steering axle scale



Off-Road

Built for extreme environments and extreme loads

Avery Weigh-Tronix Off-Road truck scales are designed to meet the tough requirements of industries such as mining and excavating.

With various widths, lengths and capacities available, you can specify the vehicles to be weighed and let Avery Weigh-Tronix take care of the rest.



Portable Truck Scales

Quick set-up for weighing almost anywhere

Avery Weigh-Tronix portable truck scales go anywhere there is an immediate need for on-site vehicle weighing. They quickly fill temporary needs when other scales fail or there are delays with foundation construction.

The self-contained modular sections eliminate costly site preparation and can be installed on any stable surface in just 2 to 4 hours. They can be readily converted for installation as permanent, low-profile scales. Also available as rental units.

Selection Guide

	BridgeMont Standard Duty	BridgeMont Heavy Duty	SteelBridge XT Extreme Duty	BridgeMont HD Portable	SteelBridge XT Portable	BridgeMont Low Profile	Off-Road
Standard Profile	14"	14"	14"	19"	19"	11.25"	☒
Gross Capacity	35,000 to 270,000 lb	40,000 to 270,000 lb	50,000 to 270,000 lb	40,000 to 270,000 lb	50,000 to 270,000 lb	40,000 to 270,000	Up to 270,000 lb
CLC/DTA	35 tons	45 tons	45 tons	45 tons	45 tons	45 tons	☒
NTEP Approved	✓	✓	✓	✓	✓	✓	✓
Standard Lengths	10' to 120'	10' to 150'	10' to 150'	20' to 100'	20' to 100'	☒	10'
Standard Widths	10', 11'	10' to 14'	10' to 14'	10', 11'	10', 11'	10', 11'	up to 20'
Custom Lengths & Widths	☒	☒	☒	☒	☒	☒	☒
Weight Sensor							
Weigh Bar - Alloy Steel	✓	✓	✓	✓	✓	✓	✓
Weigh Bar - Stainless Steel	○	○	○	○	○	○	○
ZT Digital Cell (no junction box required)	☐	☐	—	—	—	—	—
Warranty							
Weighbridge Structure	5 years	10 years	15 years	10 years	15 years	10 years	10 years
Weight Sensor							
Weigh Bar*	5 years	5 years	5 years	5 years	5 years	5 years	5 years
ZT Digital Load Cell	5 years	5 years	—	—	—	—	—
Suspension System	Easi-Post	Easi-Post	Easi-Post	Easi-Post	Easi-Post	Easi-Post	Link
Deck Surface	Steel	Steel or Concrete	Steel or Concrete	Steel	Steel	Steel	Steel or Concrete
Finish	Paint	Paint	Paint	Paint	Paint	Paint	Paint
Stainless Steel Sheathed Cable	✓	✓	✓	✓	✓	✓	✓
Stainless Steel Analog J-Box	✓	✓	✓	✓	✓	✓	✓
ZB210 Digital J-Box	○	○	○	○	○	○	○
Guide Rails	○	○	○	○	○	○	○
Manholes	—	○	○	—	—	○	○

✓ = standard ○ = optional ☒ = consult factory — = not available ☐ = optional (10' - 12' widths) * = 10-year with Blue Blanket warranty purchase





Options & Accessories

Create a complete truck scale system

Select from a wide range of options and accessories to create a powerful and versatile vehicle weighing system.

- 1 **Guide rails and posts** – Extreme-duty guide rails provide a strong barrier against accidental drive-offs. An extra tall version is available for MSHA considerations. The rails are finished with bright yellow paint to optimize visibility.
- 2 **Stop & go lights** – Help direct vehicle movement and improve safety. Rugged design withstands all types of weather and environments.
- 3 **Loop detectors** – Installed at the entrance and exit to detect vehicle weight data and ensure proper positioning.
- 4 **Remote displays** – Allow clear, comfortable viewing of scale information at considerable distances, indoors and outdoors. Available with integrated traffic light and wireless interface.
- 5 **Unattended system** – Allows 24/7 scale availability. Can be customized with options such as loop detectors, ID readers, traffic lights, and wireless communication.
 - › **Manhole** – Provides easy access in pit installations. Reinforced 2' x 2' manhole includes a heavy-duty cover to maintain truck scale integrity.
 - › **Grain dump module** – An easy-flow grate allows trucks to weigh and dump over a BridgeMont truck scale. Available in various lengths and widths.
 - › **Pre-fab foundations** – The scale and foundation can arrive on the same truck shipment to be set-up in just a few hours. If the scale needs to be relocated, the foundation can be re-used.



ETHERNET



USB



SERIAL



TS

- › **Indicators** – A range of digital indicators meet the exact needs of any truck scale application, from basic weighing to advanced transactions and data management.
- › **Digital junction box** – Convert analog load cell signal to digital outputs, offering faster calibration, remote monitoring of individual cells, connection to a PC and improved signal strength over long distances.
- › **Printers** – We offer a range of printers which will meet the needs of your truck scale operation.
- › **Software** – Our truck scale software offers powerful yet flexible truck scale management, supply chain function and business intelligence capabilities. Use the data collected to help control inventory and monitor costs while improving site efficiency and throughput.

Design Features

Exclusive design features are what make Avery Weigh-Tronix truck scales #1 in the industry.



Composite concrete design

Only the top half (5") of the deck is poured, allowing the concrete to stay in compression. Tension forces are handled by the high-strength steel structure below the concrete. Fiber-mesh concrete is specified to increase strength and resist cracking.

Factory welded studs bond the concrete to the steel structure, eliminating the need for costly and time-consuming rebar.

Concrete deck cutaway

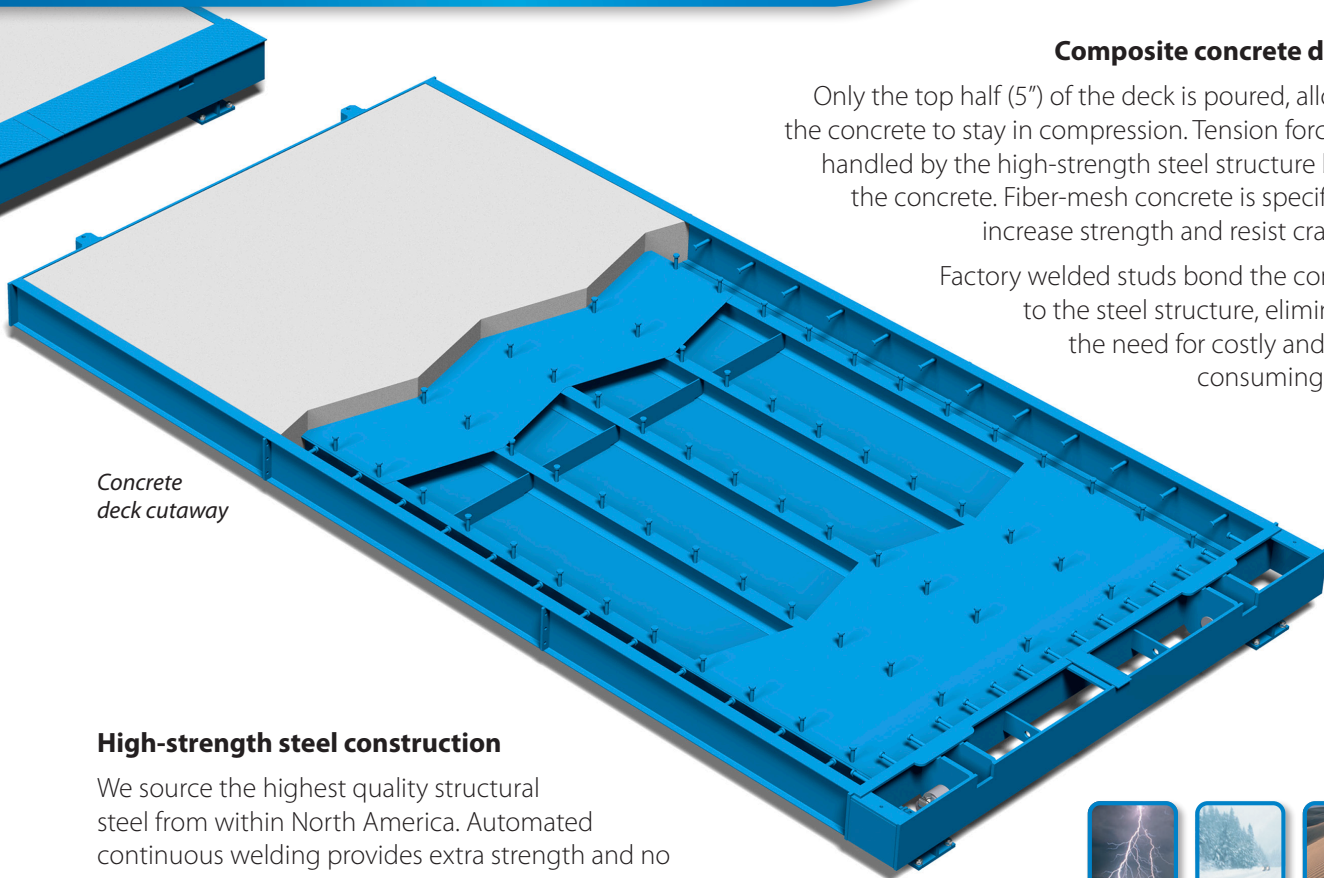

High-strength steel construction

We source the highest quality structural steel from within North America. Automated continuous welding provides extra strength and no weak spots.

Steel surface protection

A detailed surface preparation and coating process protects the scale from the elements. Individual components are shot-blasted, entire decks are sand-blasted and cleaned, then primed with a high solids urethane primer and finished with a tough, acrylic polyurethane top coat.

Low profile

14" height from baseplate to driving surface minimizes ramp requirements. Higher profile for additional clearance is easily accomplished with affordable base plate options.

No-bolt module connections

Simple hook & notch design allows quick, easy joining of the modules. Overall scale length is easily increased by adding modules.



Environmental Shielding

Environmental seals, stainless steel sheathed cable, surge protection, heavy-duty coatings and rugged construction help Avery Weigh-Tronix scales defend against Mother Nature's worst.

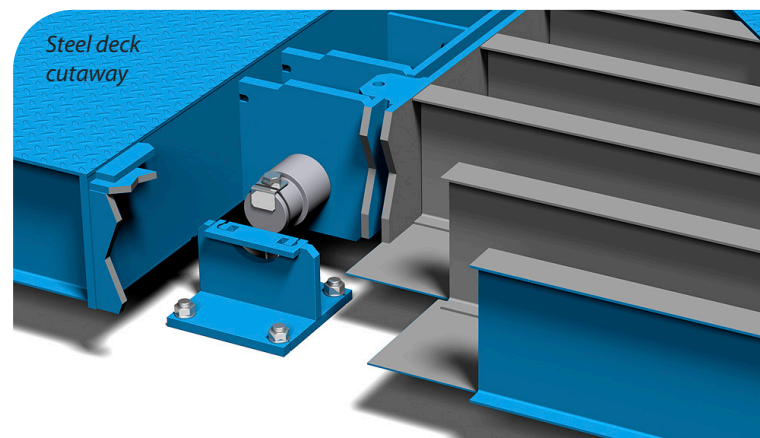

TS



Weigh Bar® Weight Sensor

A proven weight sensor

The exclusive Avery Weigh-Tronix Weigh Bar is an extremely rugged, highly reliable, load sensing device. Over several decades, the Weigh Bar has built a reputation for precision, reliability and durability that no other load cell can match.

- › **Reduced cost of ownership** – Precision machined from aircraft-quality, alloy steel, the Weigh Bar offers excellent repeatability and long-term durability, reducing cost of ownership and need for load cell replacement.
- › **Rugged** – With up to ten times more steel content than shear beams or compression cells, it absorbs impact to minimize peak forces and is virtually fatigue-proof. The Weigh Bar is proven to resist electrical surges and is protected by a 5-year warranty, expandable to 10-year with Blue Blanket warranty purchase, that includes coverage against lightning damage.
- › **Accurate** – The sensor's design automatically cancels the effects of side loading, end loading and twisting, resulting in quick, accurate readings which are achieved regardless of temperature change, vibration, and shock loads on the scale.
- › **Sealed** – The Weigh Bar is well protected against harsh environments by an exclusive 5-layer, sealing process. It is approved by Factory Mutual as intrinsically safe for hazardous locations.

Annual Load Cell Failure Rate

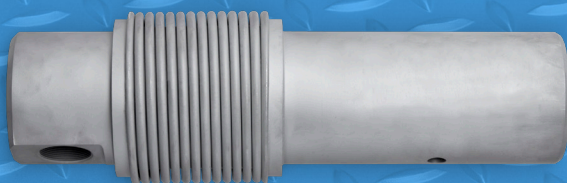
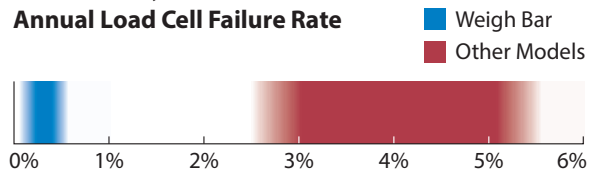

For the harshest environments, stainless steel Weigh Bars are available to provide an extra level of protection.

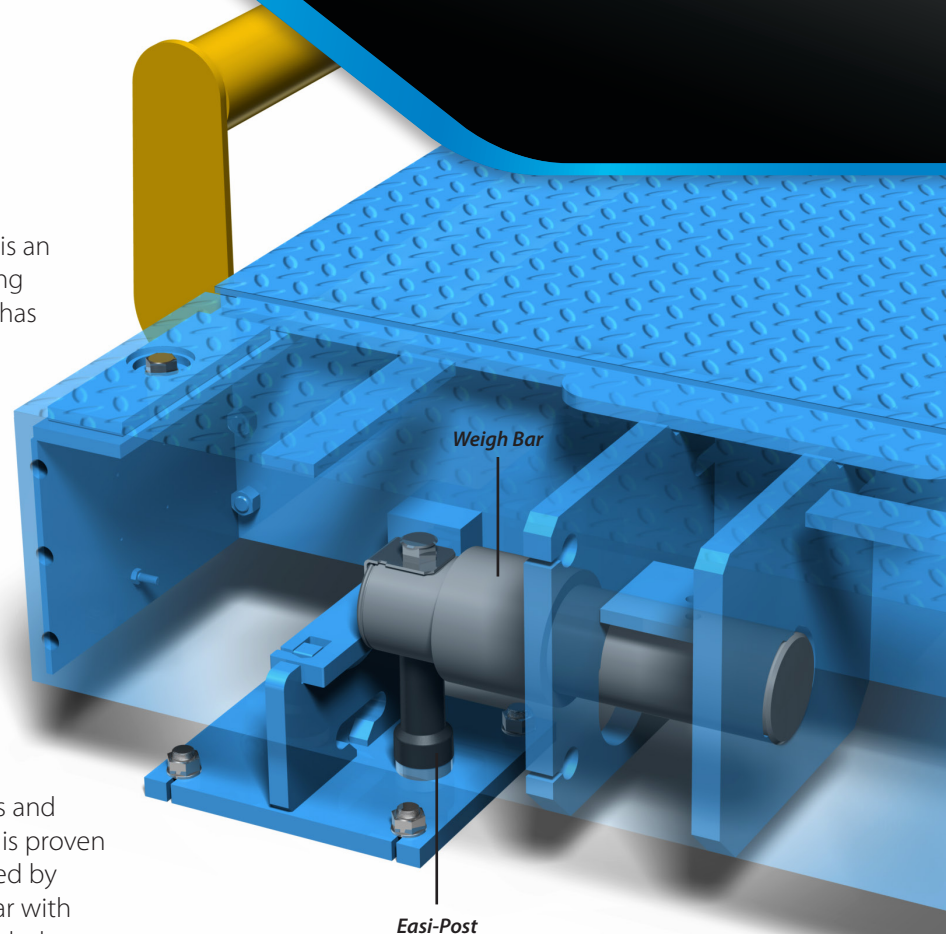

Easi-Post™ Suspension

Rugged, precise and easy to install

The Easi-Post suspension system is a proven design that offers a high degree of performance, efficiency, and durability while absorbing the energy applied to the truck scale during braking and acceleration.

Easi-Post greatly simplifies the job of leveling a scale with the foundation. Each module may be raised or lowered by ½" with a simple turn of the adjustment bolt.

- › **Strength** – The heavy-duty, stainless steel components provide long-lasting performance.
- › **Checking** – Checking systems are internal and self-aligning. They allow for deck expansion/contraction without the hassle of periodic adjustment like bumper-bolt systems.
- › **Dampening** – The patented features of Easi-Post quickly stabilize rocking motion as trucks stop and go, for fast and stable weight readings.
- › **Installation** – Base plates are anchored directly to pier tops. No grouting is necessary for proper alignment.



ZT Digital Load Cell Systems

The **ZT Digital Load Cell** is a high accuracy, hermetically sealed to IP68/69K canister cell, which connects to a smart network without the need for a junction box. Each **ZT Digital Load Cell** is factory tested and calibrated to supply outstanding weighing performance even in the world's most extreme operating conditions

- › **Intelligent system management** – The **ZT Digital Load Cell** are directly interconnected to a secure digital backbone network. This solution allows the Avery Weigh-Tronix ZM605/615 Indicators to manage up to 32 cells over two separate networks without the need for a junction box or termination plug.
- › **Fastest installation, simple calibration** – Each **ZT Digital Load Cell** is factory calibrated and supplied with ready-assembled load buttons resulting in quick and simple installation. The Amphenol LTW® X-Lok connectors make the interconnection of the **ZT Digital Load Cells** a faster, flexible and error-free operation.
- › **Smart diagnostics** – The active alarm messaging feature monitors the system to identify a fault and provides a faster turnaround for service. With the added 'Ghosting' feature, the system can be kept up and running, even when one sensor fails (non-trade approved mode only).
- › **Built to last** – The thick hermetic stainless steel wall protects the internal elements while the two-stage TVS help to neutralize the effects of lightning. The industry leading data cables have a SST overbraid and dual-screen system for maximum abrasion resistance and EMI immunity. Backed by 5-year warranty that includes coverage against lightning damage.

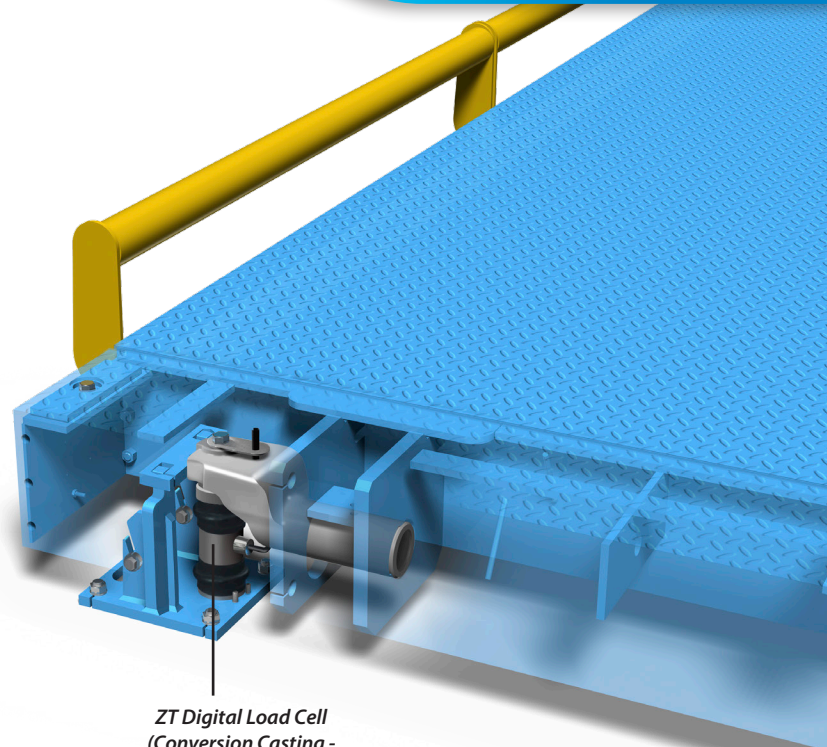

*ZT Digital Load Cell
(Conversion Casting -
only available for install
in North America)*



ZT Digital Load Cell



Avery Weigh-Tronix

www.averyweigh-tronix.com

Avery Weigh-Tronix is an ITW company