

**Avery Weigh-Tronix**

**ZB210**  
Digital Junction Box



**Installation/Service Instructions**

*AWT35-501806  
Issue AA*

**Avery Weigh-Tronix is a trademark of the Illinois Tool Works group of companies whose ultimate parent company is Illinois Tool Works Inc (“Illinois Tool Works”). Copyright © 2018 Illinois Tool Works. All rights reserved.**

No part of this publication may be reproduced by making a facsimile copy, by the making of a copy in three dimensions of a two-dimensional work and the making of a copy in two dimensions of a three-dimensional work, stored in any medium by electronic means, or transmitted in any form or by any means, including electronic, mechanical, broadcasting, recording or otherwise without the prior written consent of the copyright owner, under license, or as permitted by law.

This publication was correct at the time of going to print, however Avery Weigh-Tronix reserves the right to alter without notice the specification, design, price or conditions of supply of any product or service at any time.

# Table of Contents

	<i>page</i>
<b>Table of Contents</b> .....	3
<b>Manual revision history</b> .....	6
<b>Chapter 1 General information and warnings</b> .....	7
About this manual .....	7
Text conventions .....	7
Special messages .....	7
Installation .....	7
Routine maintenance .....	8
Training .....	8
<b>Chapter 2 Installation</b> .....	9
Overview .....	9
Retrofitting into an existing scale .....	13
Switch settings .....	19
<b>Chapter 3 Calibration procedures</b> .....	20
Accessing calibration .....	20
Calibrate .....	21
Corner Balancing .....	22
Section Weight Adjustment .....	24
Ghost feature .....	25
Sensor Swap Procedure .....	27
Sensor Orientation and Wiring .....	28
Orientation for Single Platform Truck Scales .....	29
Orientation for Multi-platform Truck Scales .....	30
<b>Chapter 4 Diagnostics and servicing the ZB210 J-Boxes</b> .....	31
Diagnostic Menu .....	31
Accessing Diagnostics .....	31
<i>About</i> menu item .....	32
<i>Corner</i> menu item .....	33
<i>Counts</i> menu item .....	33
<i>Volt</i> menu item .....	33
<i>Signal</i> menu item .....	34
Displayed warning messages from ZB210 .....	34
<b>Chapter 5 ZB210 Service parts kits</b> .....	35
<b>Chapter 6 ZB210 Error messages and troubleshooting</b> .....	36
Troubleshooting .....	36
<b>Chapter 7 Technical Illustrations</b> .....	37
ZB210 (SG or LG) Single J-Box wiring .....	37
Wiring for two ZB210 (SG or LG) J-Boxes .....	38
Wiring for three ZB210 (SG or LG) J-Boxes .....	39
Wiring for four ZB210 (SG or LG) J-Boxes .....	40
Wiring for single ZB210 (STVS) J-Box .....	41
Wiring for two ZB210 (STVS) J-Boxes .....	42
Wiring for three ZB210 (STVS) J-Boxes .....	43
Wiring for four ZB210 (STVS) J-Boxes .....	44
Wiring for RS232 .....	45





## Manual revision history

Current Issue	Date Created	Details of Changes
AA	October 2018	New manual

# 1 General information and warnings

## 1.1 About this manual

---

This manual is divided into chapters by the chapter number and the large text at the top of a page. Subsections are labeled as shown by the 1.1 and 1.1.1 headings. The names of the chapter and the next subsection level appear at the top of alternating pages of the manual to remind you of where you are in the manual. The manual name and page numbers appear at the bottom of the pages.

### 1.1.1 Text conventions

---

Key names are shown in **bold** and reflect the case of the key being described. If a key has a dual function it may be referred to by its alternate function.

Displayed messages appear in **bold italic** type and reflect the case of the displayed message.

Annunciator names appear as *italic* text and reflect the case of the annunciator.

### 1.1.2 Special messages

---

Examples of special messages you will see in this manual are defined below. The signal words have specific meanings to alert you to additional information or the relative level of hazard.



---

**CAUTION!**  
*This is a Caution symbol.*  
***Cautions give information about procedures that, if not observed, could result in damage to equipment or corruption to and loss of data.***

---

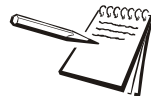

---

**NOTE:** *This is a Note symbol. Notes give additional and important information, hints and tips that help you to use your product.*

---

## 1.2 Installation

---



---

Q R #X VHU #VHUY IFHDE OH #SDUWV 1#JHIHU #NR #F X DOLI IHG #VHUY IFH #  
 SHUVR Q QHO #R U #VHUY IFH 1

---

### 1.3 Routine maintenance

---



---

**IMPORTANT:** *This equipment must be routinely checked for proper operation and calibration. Application and usage will determine the frequency of calibration required for safe operation.*

---

Always isolate the indicator from the power supply before starting any routine maintenance to avoid the possibility of electric shock.

### 1.4 Training

---

Do not attempt to operate or complete any procedure on a machine unless you have received the appropriate training or read the instruction books.

To avoid the risk of RSI (Repetitive Strain Injury), place the machine on a surface which is ergonomically satisfactory to the user. Take frequent breaks during prolonged usage.



## 2 Installation

### 2.1 Overview

---

This manual covers installation, calibration and servicing of the ZB210, the Avery Weigh-Tronix microprocessor-based digital J-Box.

Designed to meet the rigors of all outdoor and industrial environments, the ZB210 converts separate analog weight sensor signals to digital output. ZB210 J-Boxes communicate via RS485 terminals to each other and to a compatible Avery Weigh-Tronix ZM Series programmable indicator. For connection between a single ZB210 and an indicator, RS232 terminals are also available.

Each ZB210 can be connected with up to four analog weight sensors. Multiple ZB210 J-Boxes can be connected to each other, as in a truck scale application, where there are more than four weight sensors in the system.

The ZB210 is available in two different form factors. The compact ZB210-SG and ZB210-LG are used for most indoor applications. Outdoor applications such as truck scales use the ZB210-STVS with an extra layer of protection from lightning strikes.

The ZB210-SG and ZB210-LG are designed to be used with small and large deck scales. These two models have the same external dimensions, shown in [Figure 2.1](#). Their only difference is the cable gland size to accommodate large or small cables.



---

*Maximum cable lengths from analog J-Boxes to the ZB210 channels in addition to the cables attached to the Weigh Bars*

*50 feet for 350 ohm cells  
100 feet for 700 ohm cells  
140 feet for 1000 ohm cells*

*All weight sensor cables to a particular J-Box must be of relatively equal length. The difference in individual cable lengths supplied with a typical Avery Weigh-Tronix truck scale is acceptable.*

*The total cable length of 18ga. wire from the indicator to all the ZB210 boxes (including cable between ZB210 boxes) must not exceed 1000 feet when using RS485. This distance covers 1, 2, 3, and 4 box combinations.*

*For single box systems using RS232 communication, the cable length between the ZB210 and the indicator must not exceed 50 feet.*

---

Installation

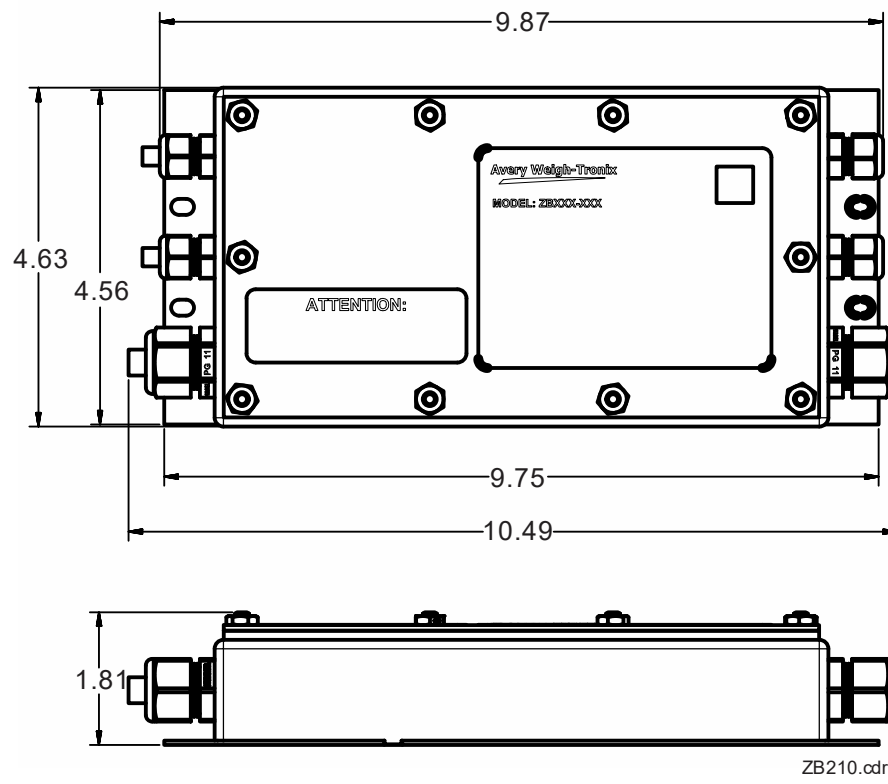

Figure 2.1 ZB210-SG and ZB210-LG external dimensions

The ZB210-STVS version's dimensions are shown in Figure 2.2.

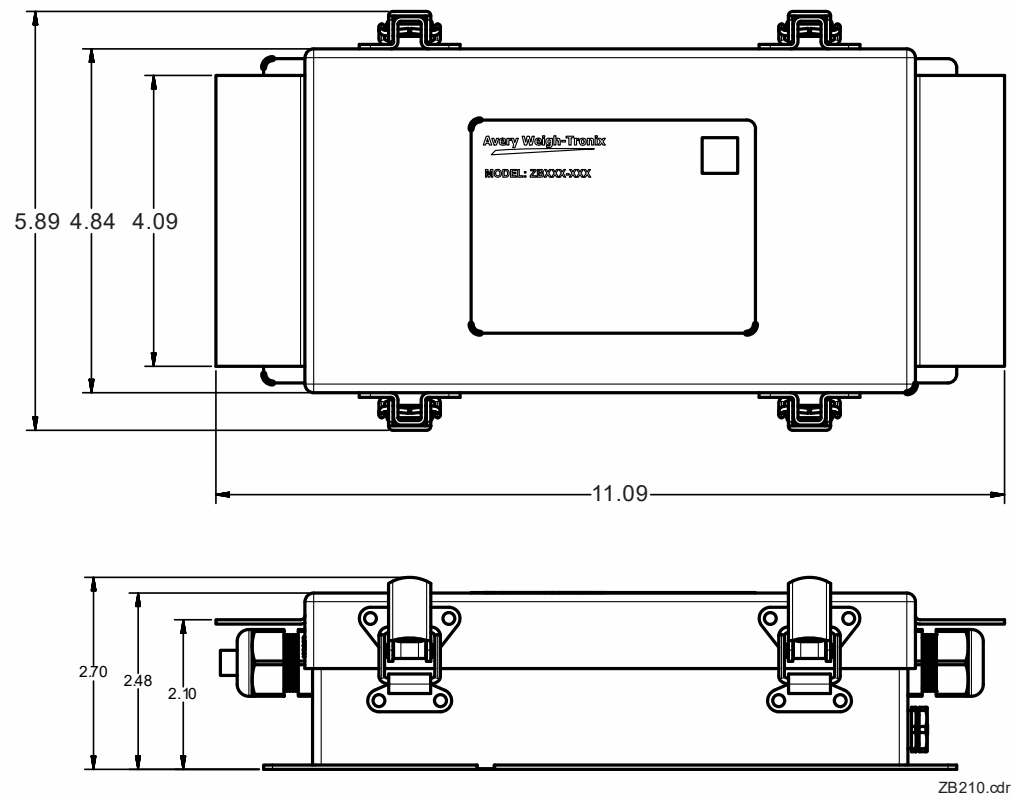
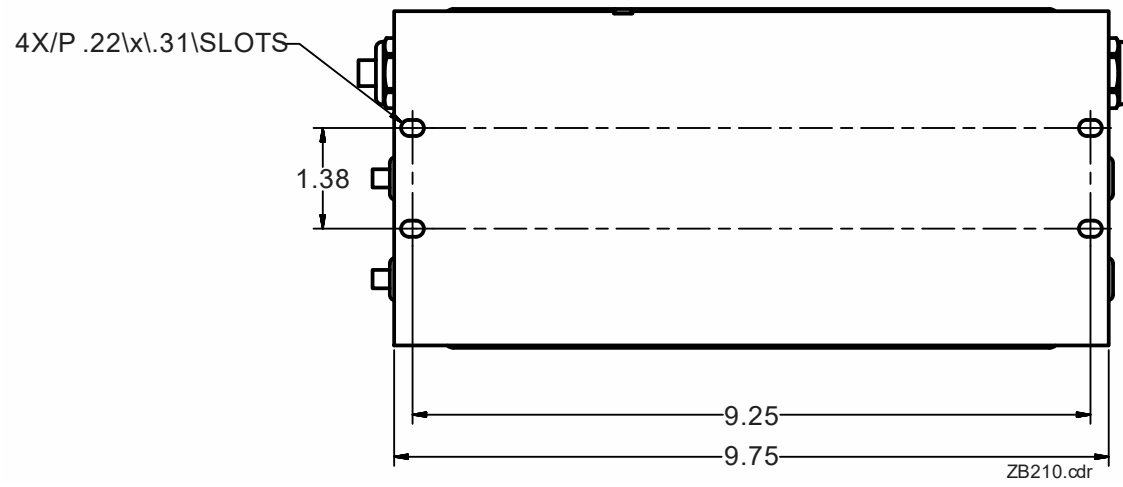
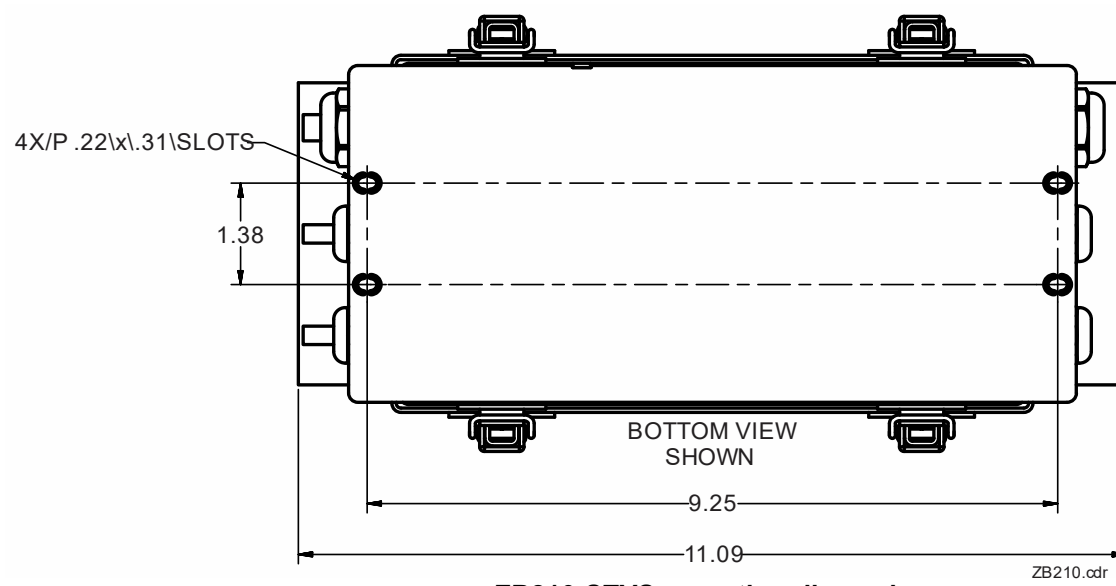

Figure 2.2 ZB210-STVS external dimensions

See the diagrams in [Figure 2.3](#) for the pattern of the holes for mounting.



**ZB210-SG and ZB210-LG mounting dimensions**



**ZB210-STVS mounting dimensions**

**Figure 2.3 Mounting hole patterns**

Installation

Figure 2.4 gives you an example of how ZB210 J-Boxes can be used.

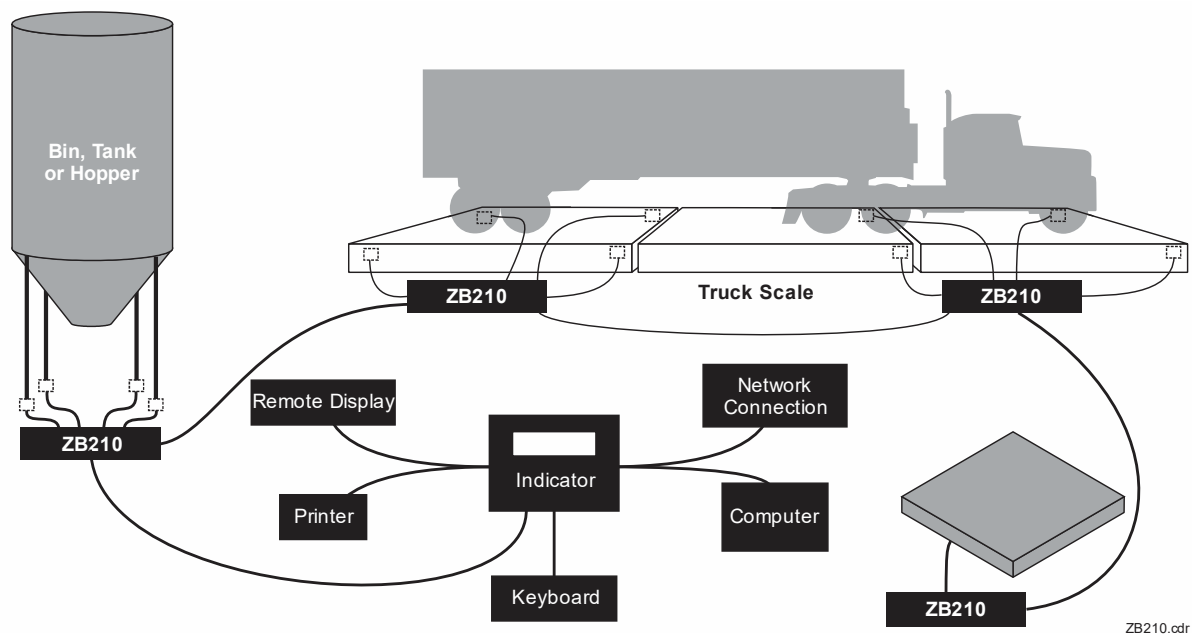

Figure 2.4 ZB210 applications

Completely separate scale systems can be daisy-chained together using this system. To do this, connect the end J-Box of one scale to the first J-Box of the next scale. See a simple example in Figure 2.5 below.

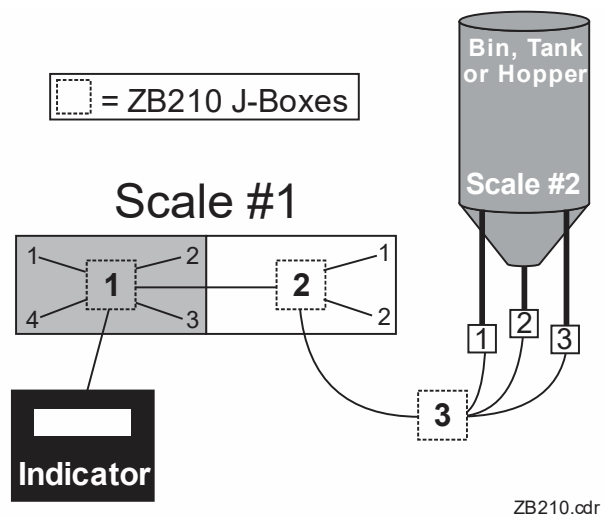

Figure 2.5 Daisy-chained ZB210 system

## 2.2 Retrofitting into an existing scale



**WARNING:** The ZB210 must be grounded to the scale assembly via metal to metal contact. The scale should also be properly grounded. A voltage suppression device is recommended for the indicator for all outdoor scale applications.

To retrofit this system into an installed truck scale, follow the steps below.

1. Access the old junction boxes, disconnect indicator interface cable and the weight sensors from the junction boxes, being sure to label the weight sensor cables as to their sensor #. See [Figure 3.6](#) for numbering convention.
2. Remove the junction boxes.
3. Connect the indicator interface cable to TB4 and TB1 in the ZB210 box and one of the indicator Comm Ports via the RS232 to RS485 board, per the chart below. Signal assignments are labeled on the PC boards, shown in [Figure 2.6](#) and repeated below.

ZB210	Signal	Wire Color	RS232 to RS485 Board & Indicator*
TB1-3	RCVA	Red	XMTA = TB2-2
TB1-4	RCVB	Green	XMTB = TB2-3
TB1-1	XMTA	Yellow	RCVA = TB2-4
TB1-2	XMTB	Blue	RCVB = TB2-5
TB4-2	GND	Black	GND = TB5-1
TB4-1	+24Vdc	White	+24V = TB5-2

ZB210.cdr

RS232 to RS485 Board  
 ZM5/6 Indicator

RS232 to RS485	Indicator
GND = TB1-1	TB3-1 (Com1) or TB3-1 (Com2) or TB6-1 (Com3)
TX = TB1-2	TB3-2 (Com1) or TB3-3 (Com2) or TB6-2 (Com3)
RX = TB1-4	TB3-4 (Com1) or TB3-5 (Com2) or TB6-4 (Com3)
+5V = TB1-6	TB3-6 (Com1) or TB3-6 (Com2) or TB6-6 (Com3)

\* Be sure to connect cable to the RS232 port configured in ZTools for ZB210.



Install sealing plugs in all unused strain reliefs.

The ZB210 allows for an RS232 connection to a ZM510, ZM605, ZM615 or ZK840 Indicator. If the S1 switches are set to enable RS232 at either 9600 or 19200 baud rate, the indicator's RS232 comm port can be wired to the ZB210's RS232 port on pins 9 (GND), 10 (TX1) and 11(RX1) on TB1. The indicator's RS232 Transmit (TX) should be connected to the ZB210's Receive (RX1); and the indicator's RS232 Receive (RX) should be connected to the ZB210's Transmit (TX1).

Installation

A Ground (GND) wire should be connected between the Indicator and ZB210, as well. It is recommended that RS232 only be used for single ZB210 installations as RS232 has limited cable driving capability as compared to RS485.

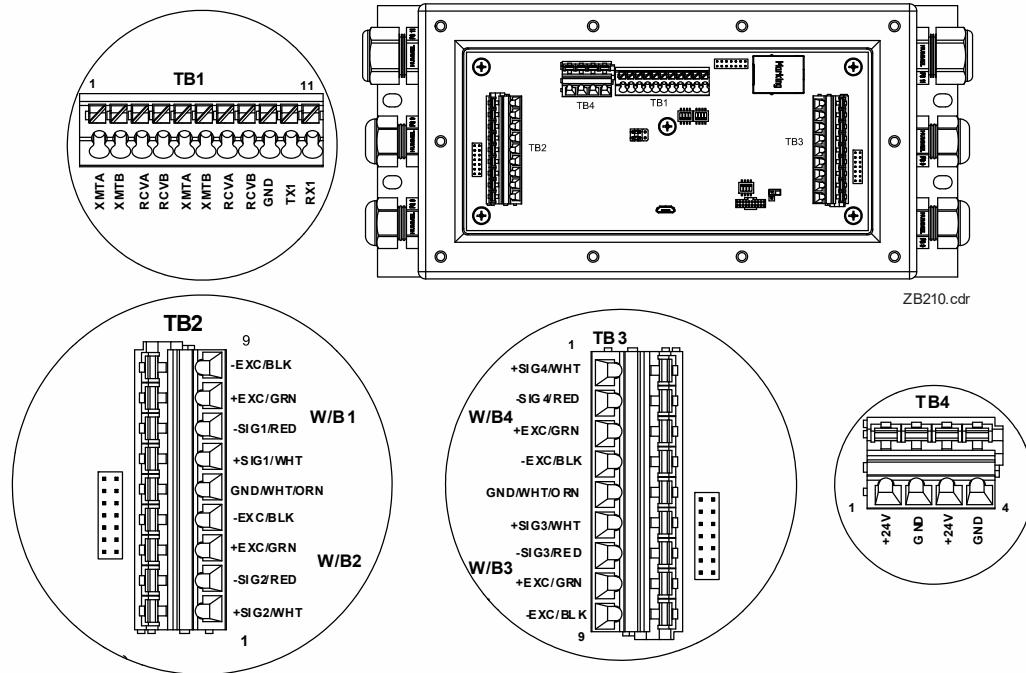

Figure 2.6 ZB210-LG and -SG junction box connections for 1st box in a chain of boxes

2.2 Retrofitting into an existing scale

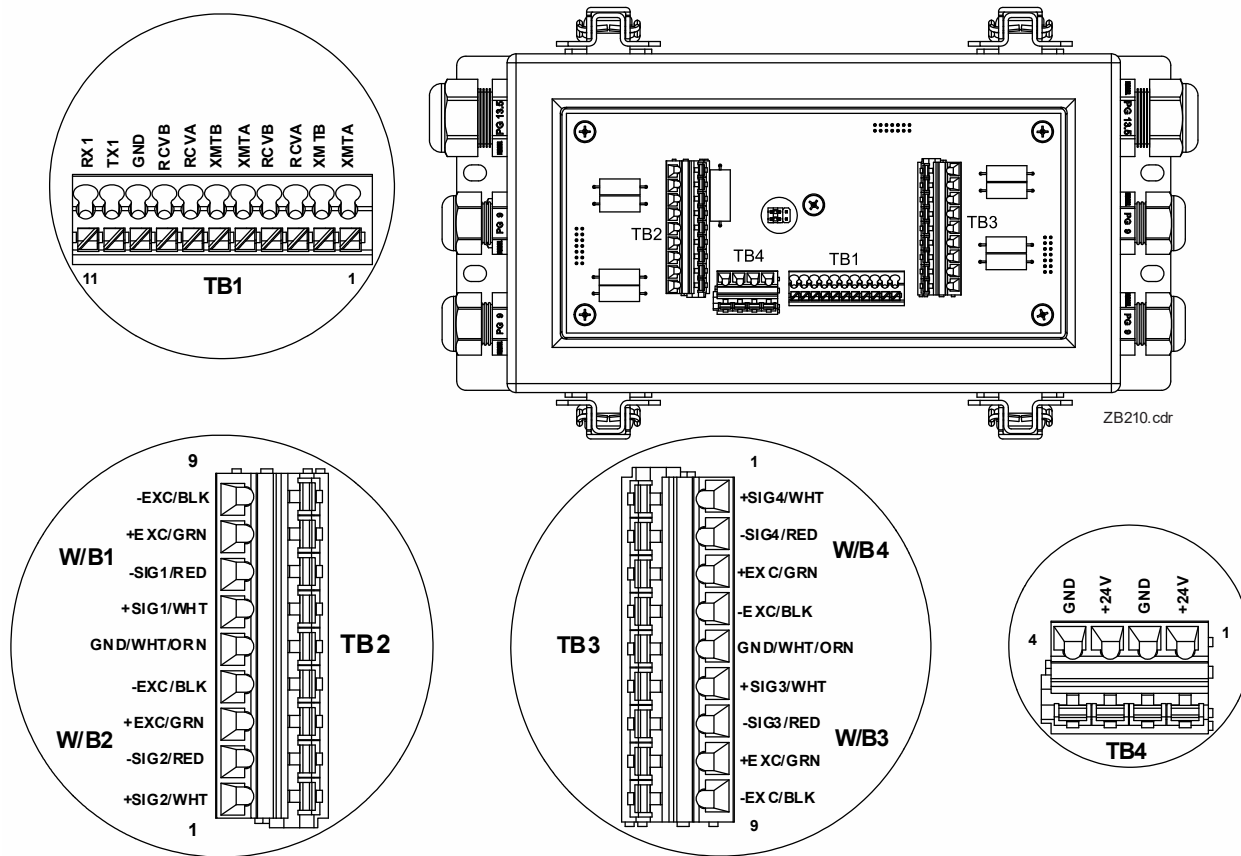

Figure 2.7 ZB210-STVS junction box connections for 1st box in a chain of boxes

4. Connect weight sensor #1 to TB2, #2 to TB2, #3 to TB3 and #4 to TB3. Pin assignments are shown below.

TB2-	Signal	Wire color	TB3-	Signal	Wire color
1	+SIG 2	White	1	+SIG 4	White
2	-SIG 2	Red	2	-SIG 4	Red
3	+EXC 2	Green	3	+EXC 4	Green
4	-EXC 2	Black	4	-EXC 4	Black
5	SHIELD	Wht/Org	5	SHIELD	Wht/Org
6	+SIG 1	White	6	+SIG 3	White
7	-SIG 1	Red	7	-SIG 3	Red
8	+EXC 1	Green	8	+EXC 3	Green
9	-EXC 1	Black	9	-EXC 3	Black

Installation

Ensure the shield of the cable installed in the indicator is grounded to the chassis of the enclosure. See the illustration below.

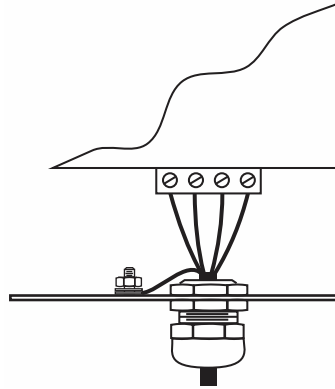

The shields of the cables installed in the ZB210 should be terminated to TB2 & TB3 pin 5. Try and make these wires as short as possible inside the ZB210 to reduce Electro Magnetic Interference (EMI). See the illustration below.

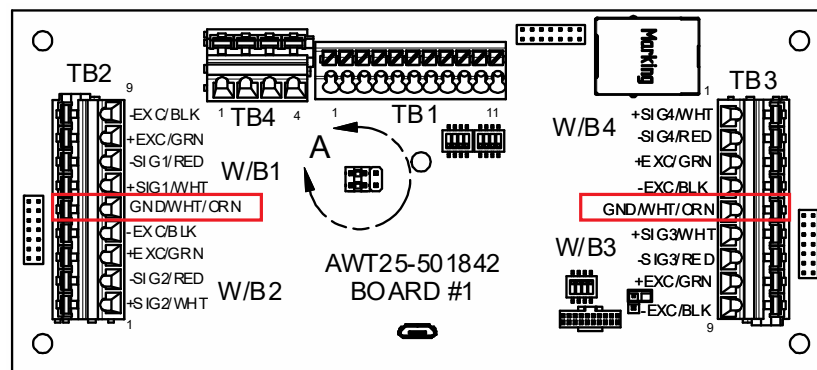



5. Set P1 jumper as shown in [Figure 2.8](#) for this first ZB210 J-Box in a series.

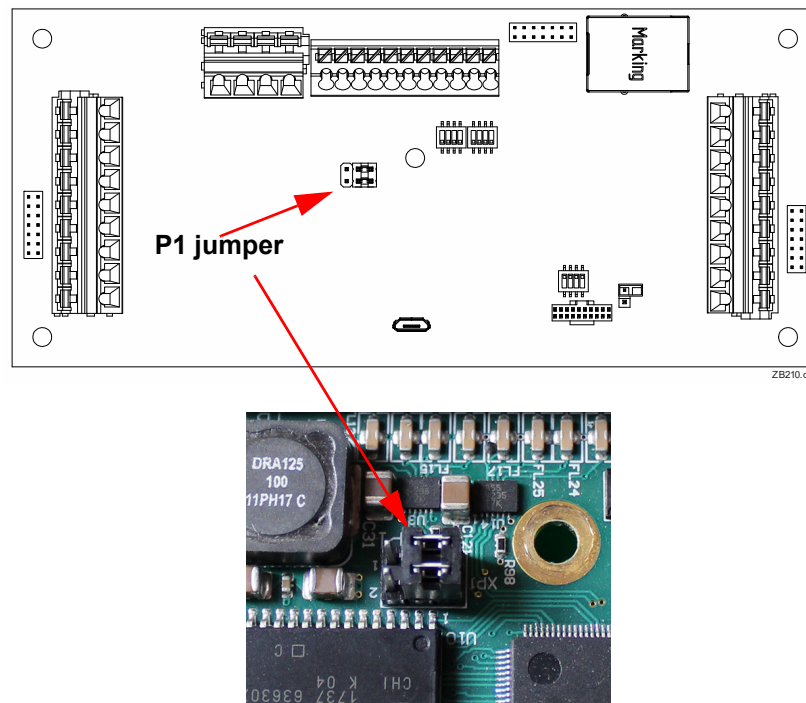
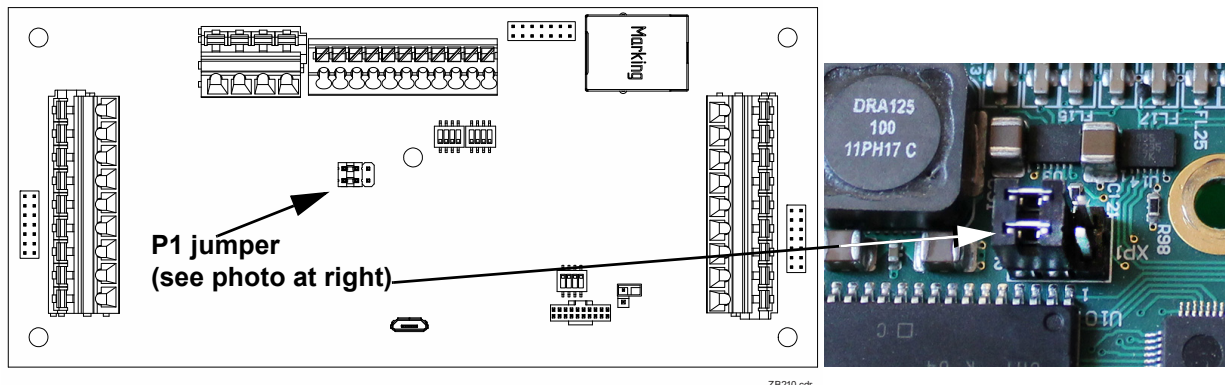

**Figure 2.8 P1 Jumper position for all ZB210 J-Boxes except the last J-Box in a chain of J-Boxes**

To connect a second ZB210 J-Box, connect the interconnecting cable to TB1 in the first ZB210, shown in [Figure 2.8](#) and connect it to TB1 in the 2nd ZB210 J-Box per the wiring labels.

ZB210 #1	Signal	Wire Color	ZB210 #2
TB1-5	RCVA	Red	TB1-3
TB1-6	RCVB	Green	TB1-4
TB1-7	XMTA	Yellow	TB1-1
TB1-8	XMTB	Blue	TB1-2
TB4-4	GND	Black	TB4-2
TB4-3	+24V	White	TB4-1

Installation



**Figure 2.9 P1 Jumper position for the last ZB210 J-Box in a chain of J-Boxes**

If it is not the end box in a chain of ZB210 J-Boxes, set the jumper as shown in [Figure 2.8](#). If it is the only J-Box or the terminal (end) J-Box in a series, set the jumpers as shown in [Figure 2.9](#).

Make sure your indicator and ZB210s are in the unsealed mode. See the [Figure 2.10](#).

Attach the remaining weight sensors to their appropriate ZB210 terminal. Place supplied plugs into any unused strain relief and tighten to 18 in/lbs to ensure NEMA 4X water tightness. A simple way to achieve this is to tighten the nut until the plug will not slide, then tighten one complete turn. Replace covers on all the J-Boxes and tighten screws to 24 inch/lbs of torque, or secure all four latches on the cover if using the STVS version.

Your system should be ready for calibration and cornering which are covered in the next section.

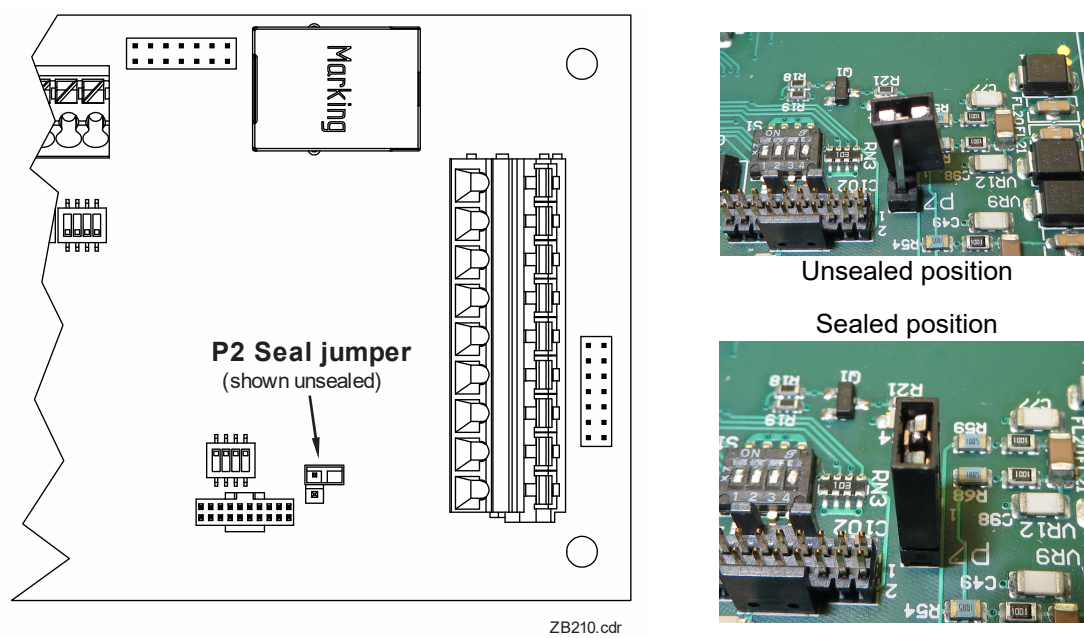

**Figure 2.10 P2 Seal jumper**

### 2.2.1 Switch settings

Below is a photo of the S1 switches. Set these according to the table shown in [Figure 2.11](#).

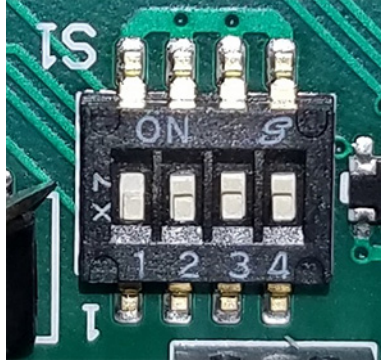

	1	2	3	4
Standard App RS485 – 19200 baud (default)	0	0	0	0
Standard App RS232 – 19200 baud	1(ON)	0	0	0
Standard App RS232 – 9600 baud	0	1(ON)	0	0
USB Bootloader	1(ON)	1(ON)	1(ON)	1 (ON)

**Figure 2.11 Switch settings**

## 3 Calibration procedures

This chapter covers calibrating a scale containing the ZB210 Digital Junction Boxes.

Follow these steps to enter the calibration mode and to corner or section balance your scale. Refer to the calibrate menu below. This example assumes a two ZB210 box, eight weight sensor system.

### 3.1 Accessing calibration

---

1. Press and hold the **SETUP** key to access the password screen.
2. Key in the ADMIN menu password, 3088, and press the **ENTER** key ...

You will see the top level of the ADMIN menu shown in [Figure 3.1](#).

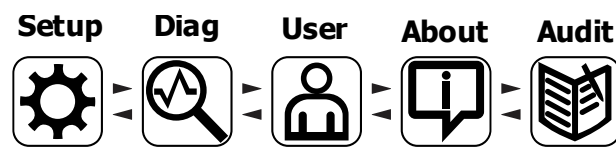

Figure 3.1 ADMIN menu top level

3. Highlight the Setup icon and press **ENTER** ...

The top level of the Setup menu is displayed. Follow the normal navigation rules to move through the items in this menu. Each item is explained below. Refer to [Figure 3.2](#).

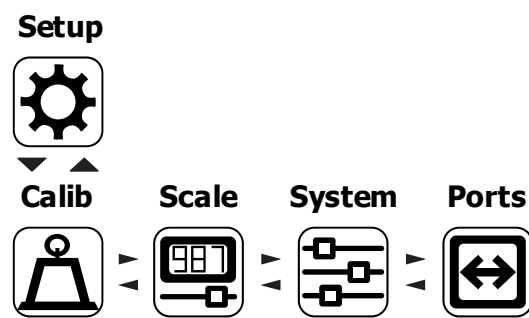

Figure 3.2 Setup menu top level

## 3.2 Calibrate

Under **Calib**, you first must choose which scale to calibrate. If there is only one scale connected, **Scale 1** is the only choice displayed. There can be up to eight scales in some indicator models.

Highlight the scale you want to calibrate and press **ENTER**. A list appears of the items under the Calib menu. Scroll down to highlight **DigJBox**. See the [Figure 3.3](#) below.



Figure 3.3 Calibration menu

Press the **F3** or **ENTER** key.

The screen shown in [Figure 3.4](#) appears.

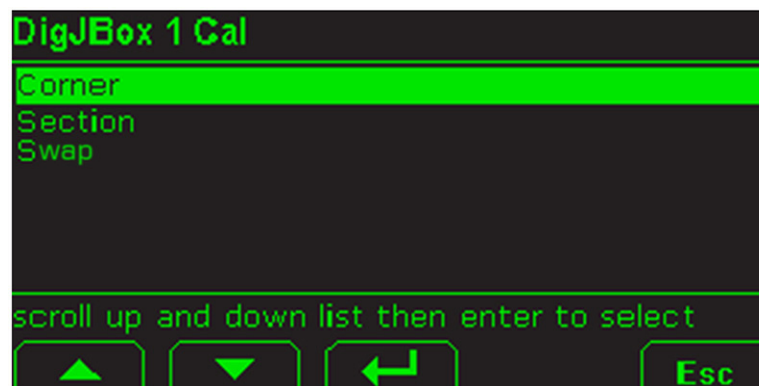

Figure 3.4 Calibration menu

The **Corner** menu item is for balancing the load cell outputs using weights placed over each corner of the scale. See [Corner Balancing on page 22](#).

The **Section** menu item is for balancing the load cell outputs using weights placed between load cells or sections of the scale. See [Section Weight Adjustment on page 24](#).

The **Swap** menu item is for replacing a bad load cell with a good one and still be assured the accuracy remains high. See [Sensor Swap Procedure on page 27](#).

See [Ghost feature on page 25](#) for information on using the ghost feature and how to do a ghost calibration.

### 3.3 Corner Balancing



As long as you use the same weight over each sensor, the system will corner correctly. Remember, a minimum of 10% scale capacity is recommended.

Ensure the scale is empty before starting the corner balancing procedure.

Highlight **Corner** and press **Enter**. You are shown the following screen. Use this to set the test weight value you will be using.

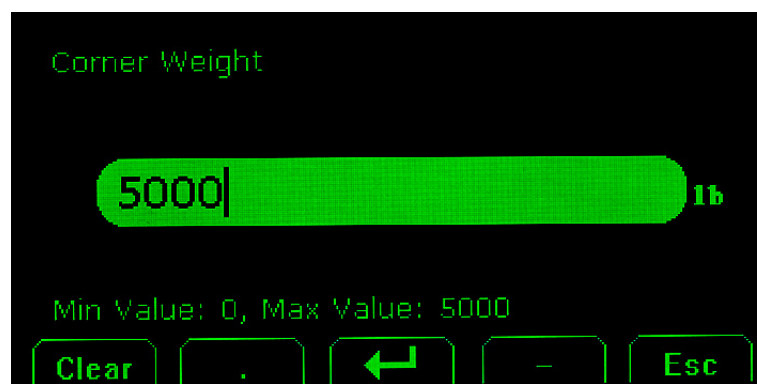

Key in the value and press **Enter**. The following screen appears.



Place the test weight over sensor #1 and press **Enter**. The screen will show that the unit is **Collecting Data** briefly, as shown below. The screen then shows the stored counts.

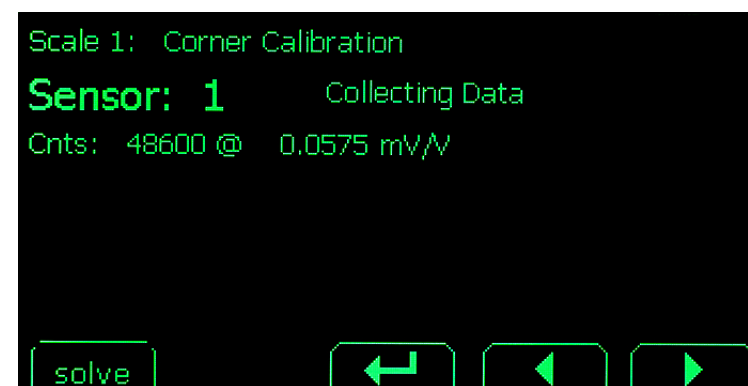

Press the right arrow key to move to Sensor 2.



Place the weight over sensor #2 and press **Enter**. Repeat this same process for all the sensors in the system.

When you are done, press the **solve** key. The unit does its calculations and shows that the process was a success:

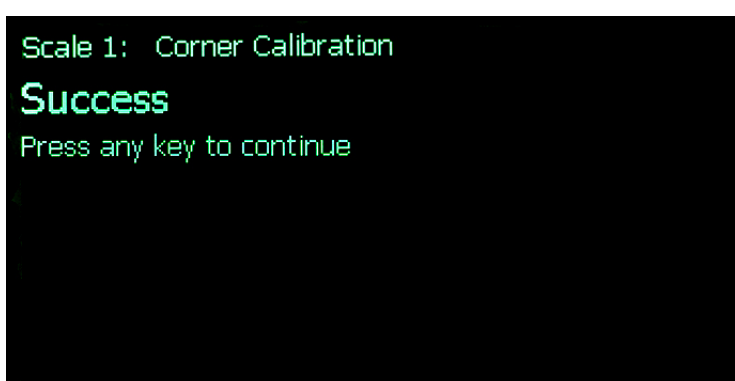

or that there was an error:

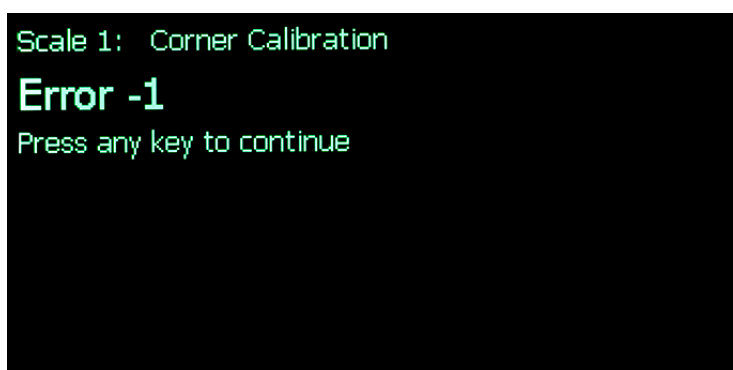

Repeat the procedure if there was an error.

When completed, you will be asked if you want to perform a Ghost calibration. Answer accordingly and follow the instructions in [Ghost feature on page 25](#). If the ghost feature activates after a sensor failure, the scale is no longer legal for trade.

When finished, follow the Zero and Span procedures in your indicator's service manual to finish the calibration.

### 3.4 Section Weight Adjustment

For optimum section calibration, enter the Weigh Bar nominal span Factors and cell capacities in ZTools before performing Section weight adjustments. If no span values are available for the sensor, you **MUST** enter **1** for a value. Leaving it at **0** disables section weight adjustment.



*As long as you use the same weight over each sensor, the system will corner correctly. Remember, a minimum of 10% scale capacity is recommended.*

Ensure the scale is empty before starting the section weight procedure. When you begin you will see a screen like the one shown below:

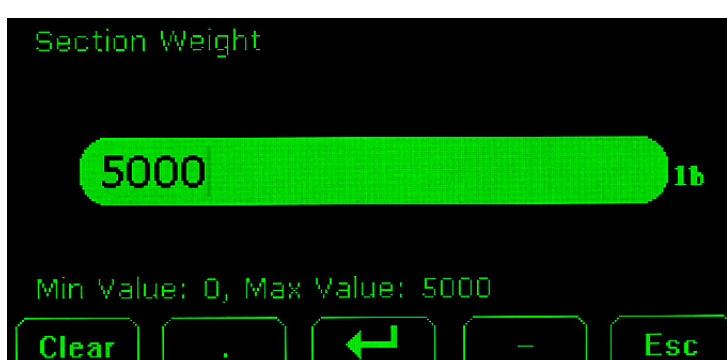

Key in a test weight value if different than the one displayed and press **Enter**.

The section #1 screen appears. Place the test weight between the sensors in section #1 and press **Enter**. The screen shows that sensor data is being collected and, when finished, shows a screen like this example:

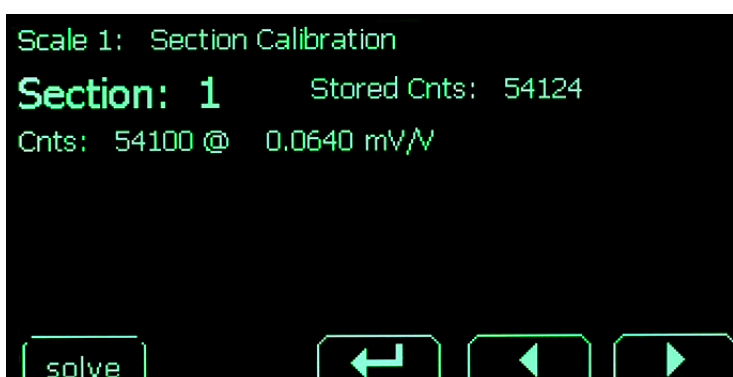



Press the right arrow key to move to Section 2 and repeat the process.



When you are done, press the **solve** key. The unit does its calculations and displays a Success message or an Error message.

If an error occurs during corner or sectional calibration, an error code is displayed. You will be prompted to review the data. If you select **No**, the calibration procedure is aborted. If you select **Yes**, you can review all the calibration points and recapture any that were not captured correctly.

When completed, you will be asked if you want to enable the ghost feature. If a sensor fails and the ghosting feature activates, the scale is no longer legal for trade.

When finished, follow the Zero and Span procedures in your indicator's service manual to finish the calibration.

### 3.5 Ghost feature

---

The ghost feature allows you to continue using the scale even if a weight sensor stops working. The scale will continue to function with reasonable accuracy until the weight sensor can be replaced.

#### **Corner Calibration:**

- A ghost calibration is necessary
- This only works on scales with four or less sensors
- Can ghost more than one sensor

#### **Section Calibration**

- No calibration necessary but you must enable it after a section calibration
- Only one sensor can be ghosted.

After a section calibration, you are asked if you want to enable the ghost feature. If you answer **Yes**, the scale will automatically compensate if a weight sensor fails.

Calibration procedures

Follow these instructions to perform a ghost calibration after a cornering calibration:

When you finish the corner calibration, you will see the following screen:

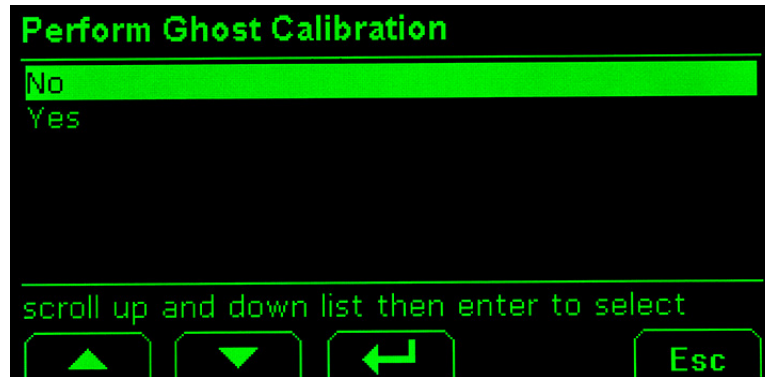

Highlight **Yes**.

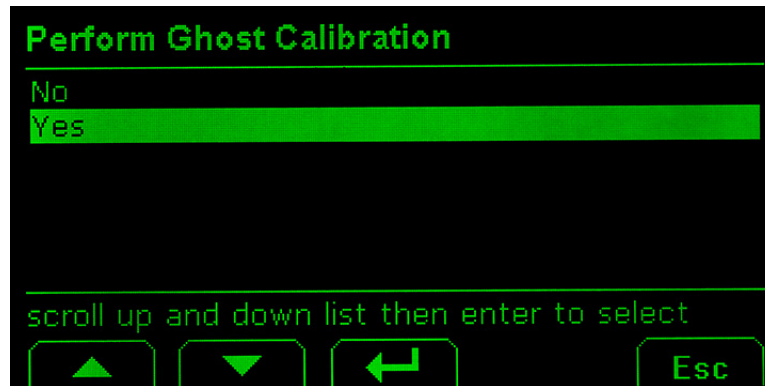

Press **Enter**.

Below is a sample of the screen you will see.

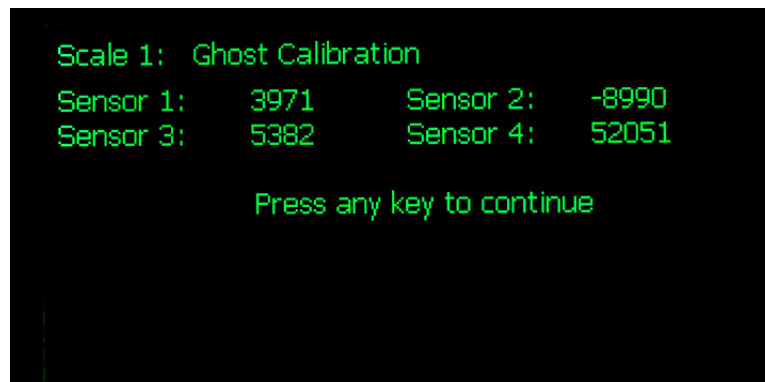

Place the test weight as close to the center of the scale as possible and press any key. **Ghost Calibration Successful** or **Ghost Calibration failed** is displayed along with **Press any key to continue**.

If the calibration failed, repeat the process.

## 3.6 Sensor Swap Procedure

The Swap process allows you to quickly and easily replace a faulty weight sensor with a new one and be confident your accuracy remains high. Follow these steps to swap weight sensors. Be aware that this procedure is not for Legal for Trade systems.

1. When you are setting up a new system in Ztools, you should enter the information for each sensor. This will allow you to perform the sensor swap in the future in case of a sensor failure.

The screenshot shows the ZB210 software interface. At the top, there is a dropdown menu for 'ZB210 Box:' set to 'Box: 1' and a checkbox for 'Set Corner Factors:' which is unchecked. Below this, the 'Sensor Name:' field is set to 'Sensor: 1'. A table lists four sensors with their respective settings:

Sensors:	Enable:	Part Number:	Serial Number:	Scale:	Output mV/V	Nominal Span:
1: Sensor: 1	<input checked="" type="checkbox"/>	111	111	#1	0.978	1.001
2: Sensor: 2						
3: Sensor: 3						
4: Sensor: 4						

Additional fields include 'Capacity:' set to 5000 and 'Corner Factor:' set to 1.

Also, the nominal span must be entered before a sectional calibration is done because the nominal span is used in the sectional calibration procedure:

2. Perform a corner or sectional calibration as explained in previous sections and exit and save changes.
3. To swap the sensor, go into the ZM setup menu and navigate to the swap menu: Setup->Calib->Scale n->DigJBox->Swap
4. Scroll to the sensor you'd like to replace. The current values for each sensor are displayed:
  - o Capacity
  - o Serial Number
  - o mV/V output
  - o nominal span
5. When you find the sensor, either press **mV/V** to key in a new mV/V output for the sensor, or press **Span** to key in a new nominal span rating. You will be prompted to key in the new sensor's:
  - o Capacity
  - o Serial number
  - o Nominal span or mV/V output (based on the key pressed)
6. After you key in the new values, they should be displayed in place of the old values for the sensor.
7. Press **F3** or **ENTER (ZERO)** to store the corner factor to the ZB210 and complete the swap. You will get a message telling you if the new values were stored successfully and you will be prompted to press a key to continue. Press any key to get you out of the swap procedure.
8. Exit the Setup menu and save changes.

### 3.7 Sensor Orientation and Wiring

---

For easiest visualization of sensor position numbers, stand on the first starting section of the base module (the section without notches to receive an adder module). While looking towards the far end of the scale, sensor number one is to your immediate left. Sensor numbering continues clockwise around the outside of the scale. The last sensor will be to your immediate right.

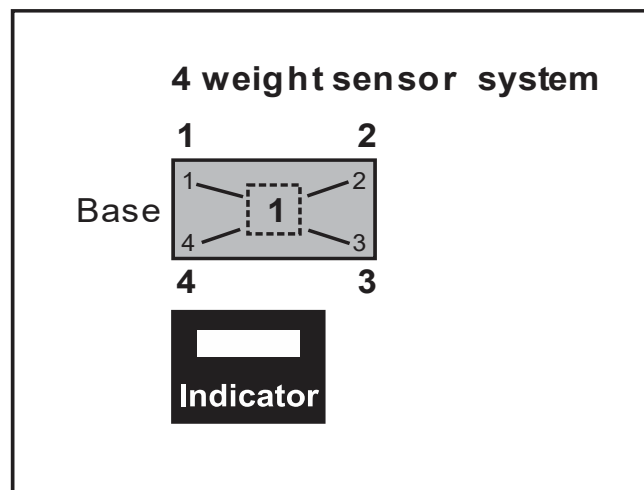

Figure 3.5 Sensor visualization

### 3.7.1 Orientation for Single Platform Truck Scales

Calibration weight sensor positions are numbered 1 through X in a clockwise direction. (X = number of bars in the system). Indicator placement is flexible.

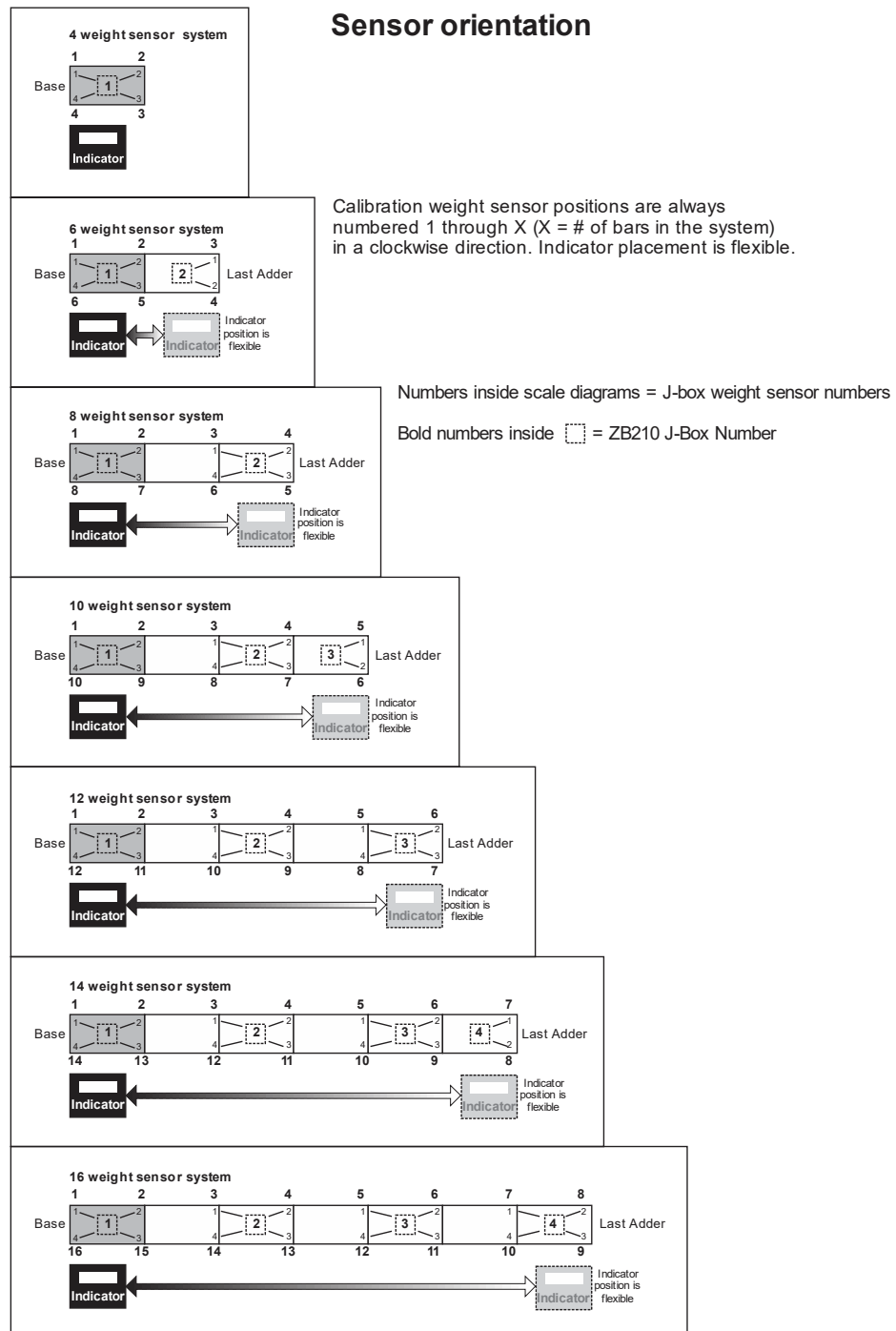
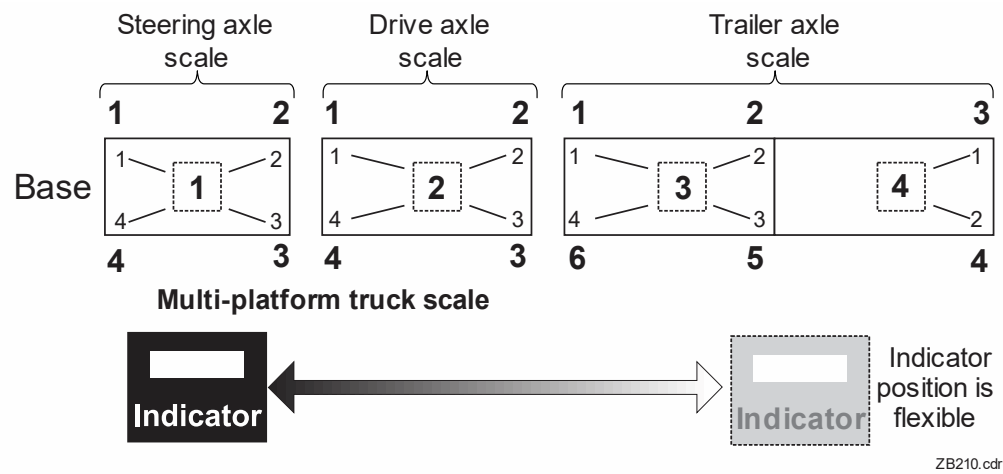

Figure 3.6 Sensor orientation numbering

### 3.7.2 Orientation for Multi-platform Truck Scales



Calibration weight sensor positions are always numbered 1 through X (X = # of bars in the system) in a clockwise direction.

Bold numbers outside the scale diagram = Calibration weight sensor numbers

Numbers inside scale diagrams = J-box weight sensor numbers

Bold numbers inside the dotted line boxes = ZB210 J-Box number-'-

## 4 Diagnostics and servicing the ZB210 J-Boxes

### 4.1 Diagnostic Menu

The indicator has a diagnostic menu to help you diagnose problems with ZB210 components. Following are the instructions you need to access this menu and explanations of each part of the menu that pertain to the ZB210 option.

### 4.2 Accessing Diagnostics

1. Press and hold the **SETUP** key to access the password screen.
2. Key in the ADMIN menu password, 3088, and press the **ENTER** key ...

You will see the top level of the ADMIN menu shown in [Figure 4.1](#).

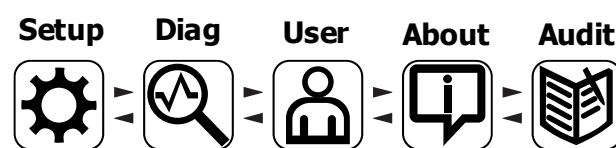

Figure 4.1 ADMIN menu top level

3. Highlight the **Diag** icon and press **ENTER** ...

The *Diagnostics* menu items are shown. Use the arrows to highlight **DigJbox**. Refer to [Figure 4.2](#) below.



Figure 4.2 Diagnostics menu

Press the **Enter** key to select **DigJbox**. The following is displayed:

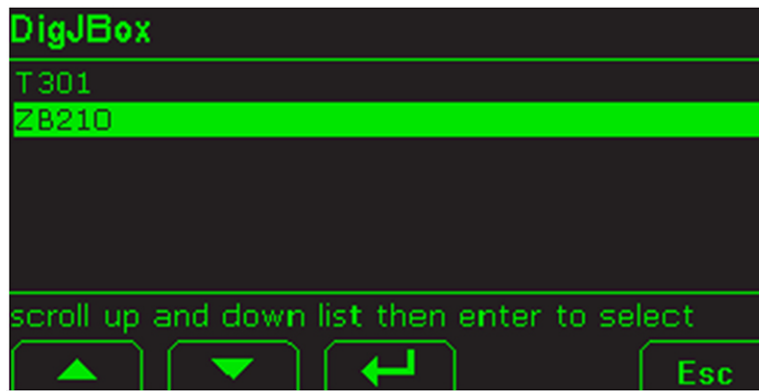

Highlight **ZB210** and press the **Enter** key. The following menu items are displayed:



Corner gives you corner factors for each.

About gives you the version.

#### **4.2.1** Derxw menu item

When you select the **About** menu item, the display shows the following information:

- The number of ZB210 boxes connected to the indicator
- The serial number of each connected ZB210
- The part number of the software in each connected ZB210
- The revision level of the software in each connected ZB210

Below is a sample screen:





#### 4.2.2 Frqhu menu item

When you select the **Corner** menu item, the display shows the corner factor for each load cell connected to the ZB210. Below is a sample screen:

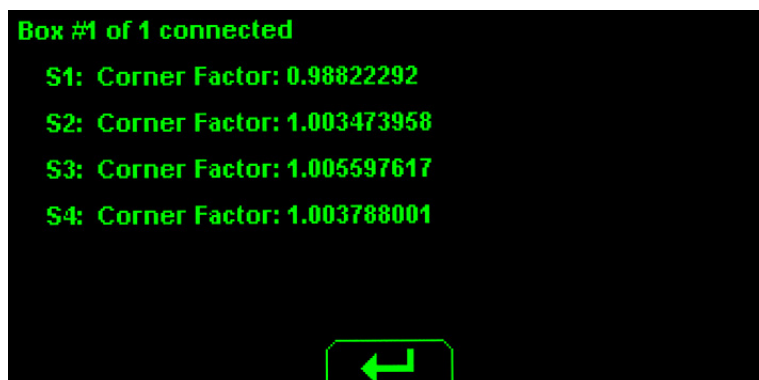

#### 4.2.3 Frxqw menu item

When you select the **Counts** menu item, the display shows the counts for each load cell connected to the ZB210. Below is a sample screen:

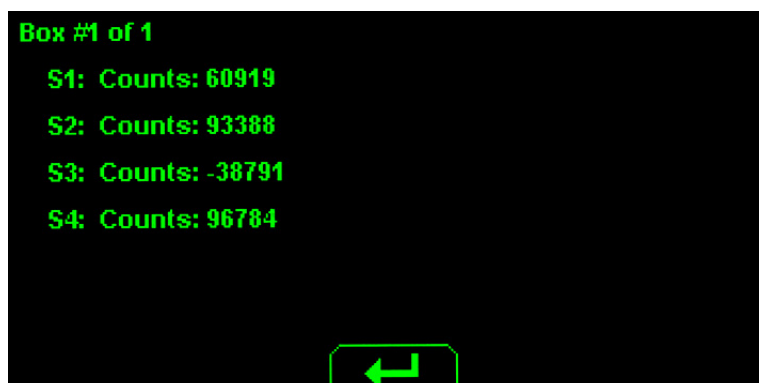

#### 4.2.4 Yrøw menu item

When you select the **Volt** menu item, the display shows the number of ZB210 J-Boxes connected to the indicator and the voltage for each load cell connected to the ZB210. Below is a sample screen:

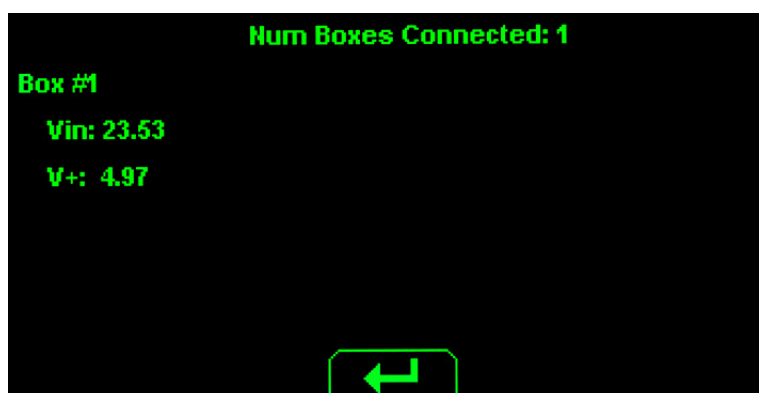

#### 4.2.5 Signal strength menu item

When you select the **Signal** menu item, the display shows the percentage of signal packets being transmitted/received between the ZB210 and the indicator. This is a diagnostic for the strength of the signal connection between the two devices. Below is a sample screen:

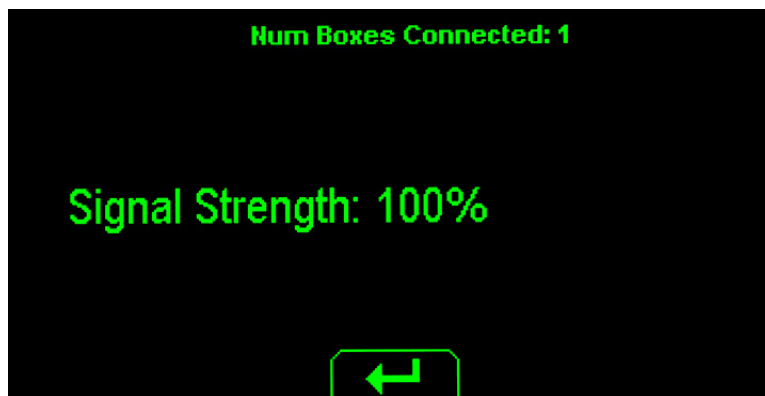

#### 4.3 Displayed warning messages from ZB210

You may see the warning messages listed in the table below. Also listed is a description of the error and possible causes. These may help with servicing.

All messages below which mention components are referring to components within the ZB210 product.

Displayed message #	Error	Description of Error	Possible Cause
ZB210 Error	Communications error	ZB210 is not responding (see Section 6 for more detailed trouble shooting)	- Cable Wiring - ZB210 Hardware Failure - Indicator Hardware failure
ZB210 Power	Power fault	+Vin, +EXC, or -EXC has fallen out of tolerance.	- Weigh Sensor Cable Wiring - Power Supply Failure
ZB210 Over	A to D overrange	More than +5mV/V has been applied to the A to D converter	- Weigh Sensor Cable Wiring - Weigh sensor - ZB210 Hardware Failure
ZB210 Under	A to D underrange	Less than 15mV/V has been applied to the A to D converter	- Weigh Sensor Cable Wiring - Weigh sensor - ZB210 Hardware Failure

Additional errors are logged in the ZB210 error log which can be accessed in a LUA application. Other LUA functionality is available to get additional status information from the ZB210. This information can also be displayed by the LUA application, if desired.

## 5 ZB210 Service parts kits

AWT05-509328	SERVICE KIT, ZB210, COVER PLATE	Cover, gasket, and nuts for replacing missing cover on a ZB210-SG or ZB210-LG.
AWT05-509327	SERVICE KIT, ZB210-LG, ENCLOSURE	Replacement enclosure for the ZB210-LG. Cover and main board NOT included.
AWT05-509326	SERVICE KIT ZB210-SG, ENCLOSURE	Replacement enclosure for the ZB210-SG. Cover and main board NOT included.
AWT05-509325	SERVICE KIT, ZB210-STVS ENCLOSURE	Replacement enclosure for the ZB210-STVS with cover. Main board and STVS board NOT included.
AWT05-509321	SERVICE KIT, ZB210-STVS BOARD	Replacement STVS input board for the ZB210-STVS
AWT05-509320	SERVICE KIT, ZB210 MAIN BOARD	Replacement main board for all ZB210 models.
AWT05-509334	SERVICE KIT, RS485 TO RS232 CONVERTER, FULL DUPLEX	Converter installed in ZM Indicator to use RS485 Communications.

## 6 ZB210 Error messages and troubleshooting

### 6.1 Troubleshooting

---

1. Conduct Loop/No Loop test on the COM port being used on the indicator and the I/O cable. Disconnect the following wires from the ZB210 board. Twist wires XMTA to RCVA and XMTB to RCVB. Use the Diagnostic menu in the indicator to verify cable and port function.

**Passed** - Replace ZB210 board.

**Failed** - Go to step 2.

2. Repeat Loop/No Loop test of the indicator's COM port on the PC board by placing a jumper wire from XMTA to RCVA and XMTB to RCVB. Use the Diagnostic menu in the indicator to verify port function.

**Passed** - Replace I/O cable.

**Failed** - Go to step 3.

3. Test the indicator's RS232 port by placing a jumper wire from TX to RX. Use the Diagnostic menu in the indicator to verify port function.

**Failed** - Replace the indicator's main board.

# 7 Technical Illustrations

## 7.1 ZB210 (SG or LG) Single J-Box wiring

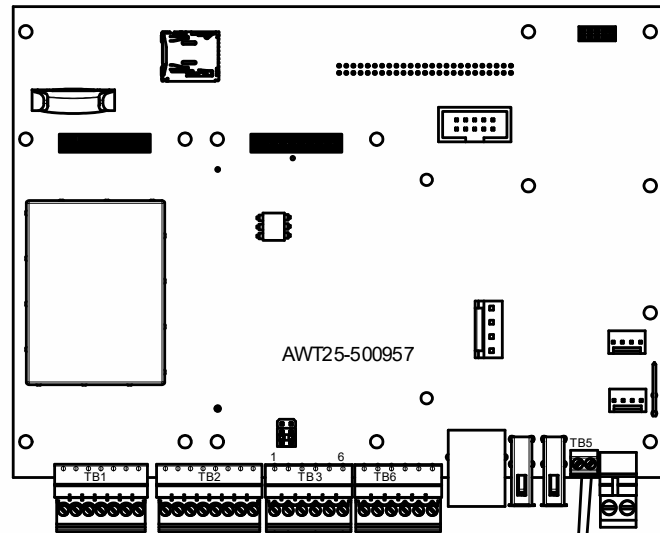

	Start				Wire		End			
	Board	Desc.	TB	Signal	Cable	Color	Board	Desc.	TB	Signal
Cable #1	AWT25-500957	ZM5/6 Main Board	TB3-1	GND (0V)	JUMPER WIRE *	BLACK	AWT25-502416	RS232-to-RS485 Board	TB1-1	GND (0V)
	AWT25-500957	ZM5/6 Main Board	TB3-2	TX1	JUMPER WIRE *	RED	AWT25-502416	RS232-to-RS485 Board	TB1-2	RX1
	AWT25-500957	ZM5/6 Main Board	TB3-4	RX1	JUMPER WIRE *	GREEN	AWT25-502416	RS232-to-RS485 Board	TB1-4	TX1
	AWT25-500957	ZM5/6 Main Board	TB3-6	+5V	JUMPER WIRE *	WHITE	AWT25-502416	RS232-to-RS485 Board	TB1-6	+5V
Cable #2	AWT25-502416	RS232-to-RS485 Board	TB2-2	XMTA	50473-0128	RED	AWT25-501842	ZB210 Main Board #1	TB1-3	RCVA
	AWT25-502416	RS232-to-RS485 Board	TB2-3	XMTB	50473-0128	GREEN	AWT25-501842	ZB210 Main Board #1	TB1-4	RCVB
	AWT25-502416	RS232-to-RS485 Board	TB2-4	RCVA	50473-0128	YELLOW	AWT25-501842	ZB210 Main Board #1	TB1-1	XMTA
	AWT25-502416	RS232-to-RS485 Board	TB2-5	RCVB	50473-0128	BLUE	AWT25-501842	ZB210 Main Board #1	TB1-2	XTMB
	AWT25-500957	ZM5/6 Main Board	TB5-1	+24V	50473-0128	WHITE	AWT25-501842	ZB210 Main Board #1	TB4-1	+24V
	AWT25-500957	ZM5/6 Main Board	TB5-2	GND (0V)	50473-0128	BLACK	AWT25-501842	ZB210 Main Board #1	TB4-2	GND (0V)

\* CUT JUMPER WIRE FROM 50473-0128 CABLE

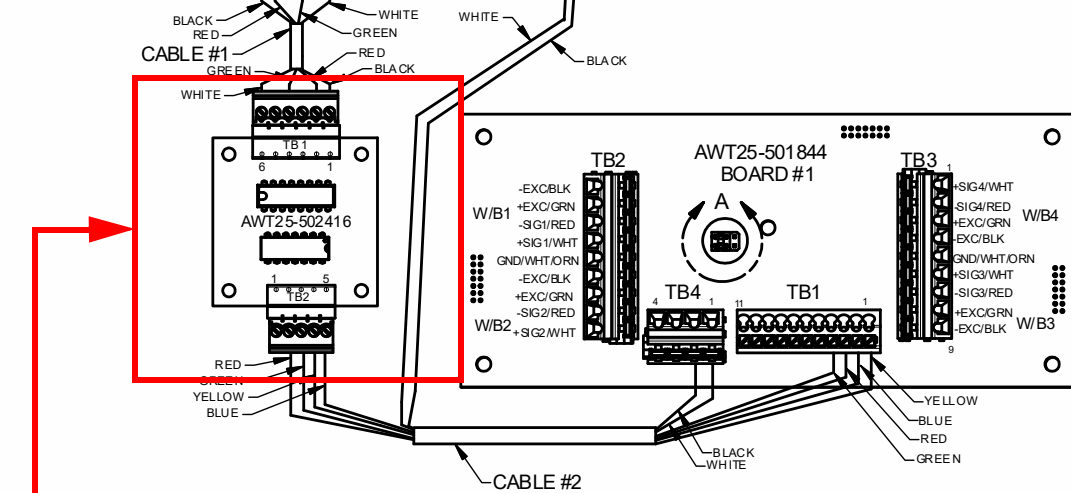

RS485 to RS232 converter board installed inside the ZM Indicator.

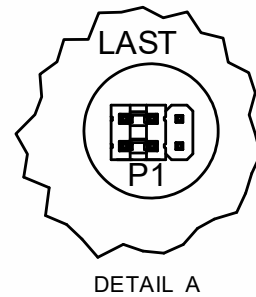

## 7.2 Wiring for two ZB210 (SG or LG) J-Boxes

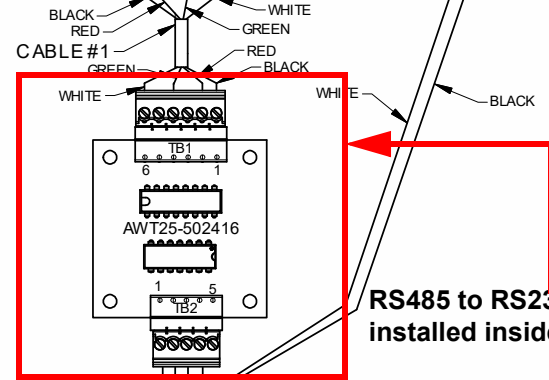
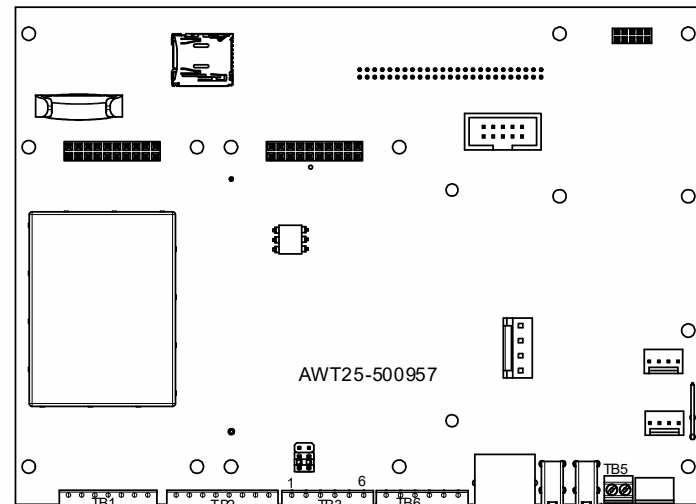

RS485 to RS232 converter board installed inside the ZM Indicator.

	Start				Wire		End			
	Board	Desc.	TB	Signal	Cable	Color	Board	Desc.	TB	Signal
Cable #1	AWT25-500957	ZM5/6 Main Board	TB3-1	GND (0V)	JUMPER WIRE *	BLACK	AWT25-502416	RS232-to-RS485 Board	TB1-1	GND (0V)
	AWT25-500957	ZM5/6 Main Board	TB3-2	TX1	JUMPER WIRE *	RED	AWT25-502416	RS232-to-RS485 Board	TB1-2	RX1
	AWT25-500957	ZM5/6 Main Board	TB3-4	RX1	JUMPER WIRE *	GREEN	AWT25-502416	RS232-to-RS485 Board	TB1-4	TX1
	AWT25-500957	ZM5/6 Main Board	TB3-6	+5V	JUMPER WIRE *	WHITE	AWT25-502416	RS232-to-RS485 Board	TB1-6	+5V
Cable #2	AWT25-502416	RS232-to-RS485 Board	TB2-2	XMTA	50473-0128	RED	AWT25-501842	ZB210 Main Board #1	TB1-3	RCVA
	AWT25-502416	RS232-to-RS485 Board	TB2-3	XMTB	50473-0128	GREEN	AWT25-501842	ZB210 Main Board #1	TB1-4	RCVB
	AWT25-502416	RS232-to-RS485 Board	TB2-4	RCVA	50473-0128	YELLOW	AWT25-501842	ZB210 Main Board #1	TB1-1	XMTA
	AWT25-502416	RS232-to-RS485 Board	TB2-5	RCVB	50473-0128	BLUE	AWT25-501842	ZB210 Main Board #1	TB1-2	XTMB
	AWT25-500957	ZM5/6 Main Board	TB5-1	+24V	50473-0128	WHITE	AWT25-501842	ZB210 Main Board #1	TB4-1	+24V
Cable #3	AWT25-500957	ZM5/6 Main Board	TB5-2	GND (0V)	50473-0128	BLACK	AWT25-501842	ZB210 Main Board #1	TB4-2	GND (0V)
	AWT25-501842	ZB210 Main Board #1	TB1-5	XMTA2	50473-0094	RED	AWT25-501842	ZB210 Main Board #2	TB1-3	RCVA
	AWT25-501842	ZB210 Main Board #1	TB1-6	XMTB2	50473-0094	GREEN	AWT25-501842	ZB210 Main Board #2	TB1-4	RCVB
	AWT25-501842	ZB210 Main Board #1	TB1-7	RCVA2	50473-0094	YELLOW	AWT25-501842	ZB210 Main Board #2	TB1-1	XMTA
	AWT25-501842	ZB210 Main Board #1	TB1-8	RCVB2	50473-0094	BLUE	AWT25-501842	ZB210 Main Board #2	TB1-2	XTMB
	AWT25-501842	ZB210 Main Board #1	TB4-3	+24V	50473-0094	WHITE	AWT25-501842	ZB210 Main Board #2	TB4-1	+24V
	AWT25-501842	ZB210 Main Board #1	TB4-4	GND (0V)	50473-0094	BLACK	AWT25-501842	ZB210 Main Board #2	TB4-2	GND (0V)

\* CUT JUMPER WIRE FROM 50473-0128 CABLE

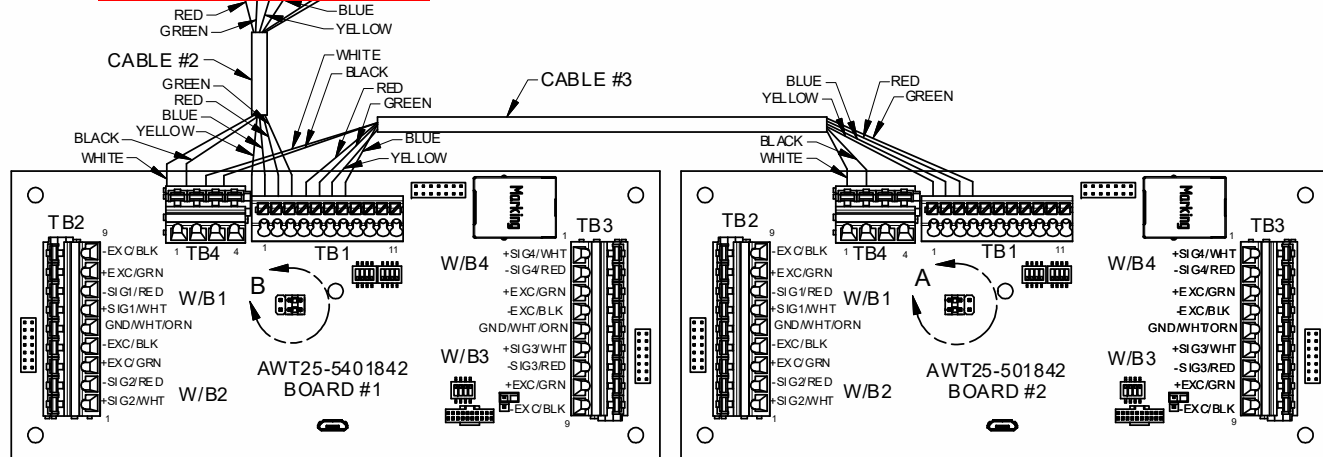

ZB210.cdr

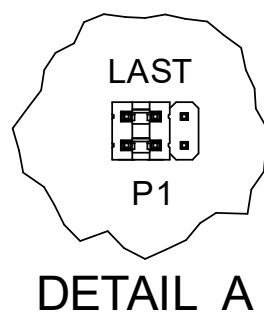
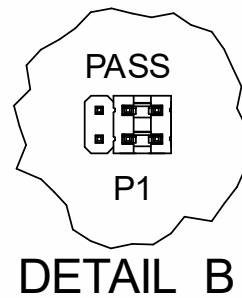

### 7.3 Wiring for three ZB210 (SG or LG) J-Boxes

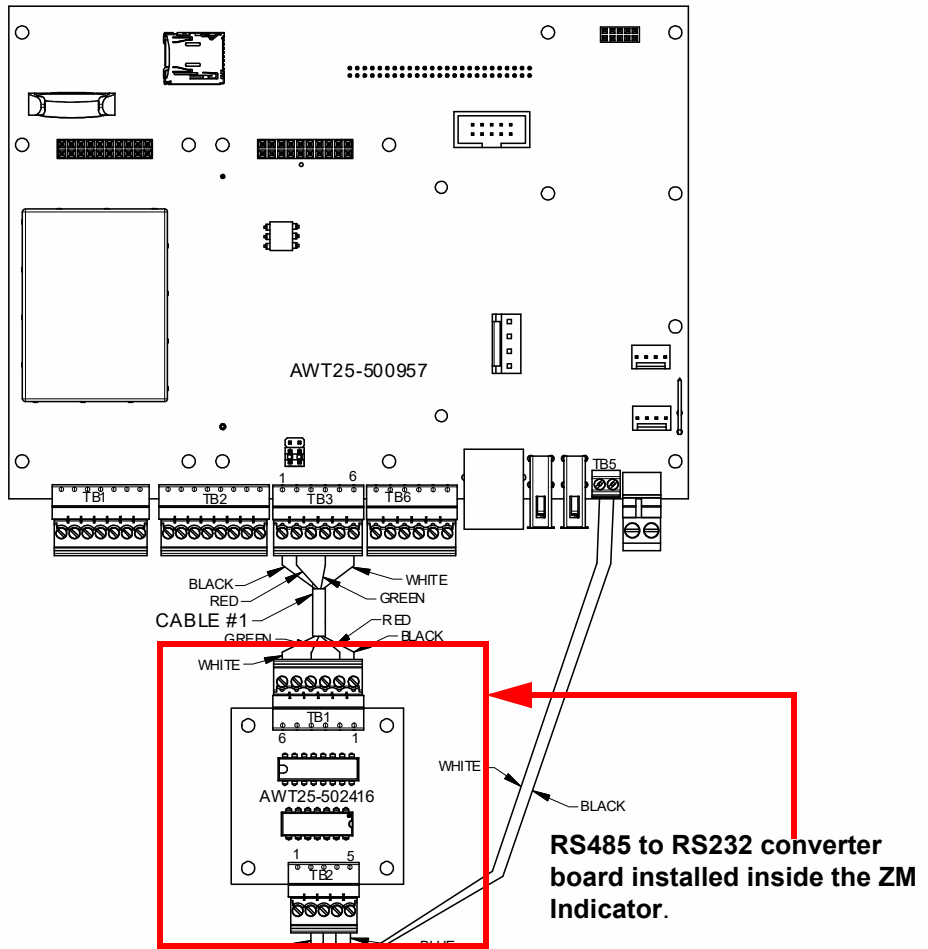

	Start				Wire		End			
	Board	Desc.	TB	Signal	Cable	Color	Board	Desc.	TB	Signal
Cable #1	AWT25-500957	ZM5/6 Main Board	TB3-1	GND (0V)	JUMPER WIRE *	BLACK	AWT25-502416	RS232-to-RS485 Board	TB1-1	GND (0V)
	AWT25-500957	ZM5/6 Main Board	TB3-2	TX1	JUMPER WIRE *	RED	AWT25-502416	RS232-to-RS485 Board	TB1-2	RX1
	AWT25-500957	ZM5/6 Main Board	TB3-4	RX1	JUMPER WIRE *	GREEN	AWT25-502416	RS232-to-RS485 Board	TB1-4	TX1
	AWT25-500957	ZM5/6 Main Board	TB3-6	+5V	JUMPER WIRE *	WHITE	AWT25-502416	RS232-to-RS485 Board	TB1-6	+5V
Cable #2	AWT25-502416	RS232-to-RS485 Board	TB2-2	XMTA	50473-0128	RED	AWT25-501842	ZB210 Main Board #1	TB1-3	RCVA
	AWT25-502416	RS232-to-RS485 Board	TB2-3	XMTB	50473-0128	GREEN	AWT25-501842	ZB210 Main Board #1	TB1-4	RCVB
	AWT25-502416	RS232-to-RS485 Board	TB2-4	RCVA	50473-0128	YELLOW	AWT25-501842	ZB210 Main Board #1	TB1-1	XMTA
	AWT25-502416	RS232-to-RS485 Board	TB2-5	RCVB	50473-0128	BLUE	AWT25-501842	ZB210 Main Board #1	TB1-2	XTMB
	AWT25-500957	ZM5/6 Main Board	TB5-1	+24V	50473-0128	WHITE	AWT25-501842	ZB210 Main Board #1	TB4-1	+24V
	AWT25-500957	ZM5/6 Main Board	TB5-2	GND (0V)	50473-0128	BLACK	AWT25-501842	ZB210 Main Board #1	TB4-2	GND (0V)
Cable #3	AWT25-501842	ZB210 Main Board #1	TB1-5	XMTA2	50473-0094	RED	AWT25-501842	ZB210 Main Board #2	TB1-3	RCVA
	AWT25-501842	ZB210 Main Board #1	TB1-6	XMTB2	50473-0094	GREEN	AWT25-501842	ZB210 Main Board #2	TB1-4	RCVB
	AWT25-501842	ZB210 Main Board #1	TB1-7	RCVA2	50473-0094	YELLOW	AWT25-501842	ZB210 Main Board #2	TB1-1	XMTA
	AWT25-501842	ZB210 Main Board #1	TB1-8	RCVB2	50473-0094	BLUE	AWT25-501842	ZB210 Main Board #2	TB1-2	XTMB
	AWT25-501842	ZB210 Main Board #1	TB4-3	+24V	50473-0094	WHITE	AWT25-501842	ZB210 Main Board #2	TB4-1	+24V
	AWT25-501842	ZB210 Main Board #1	TB4-4	GND (0V)	50473-0094	BLACK	AWT25-501842	ZB210 Main Board #2	TB4-2	GND (0V)

\* CUT JUMPER WIRE FROM 50473-0128 CABLE

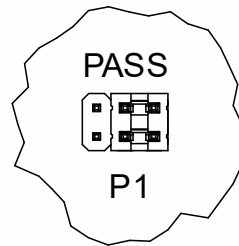
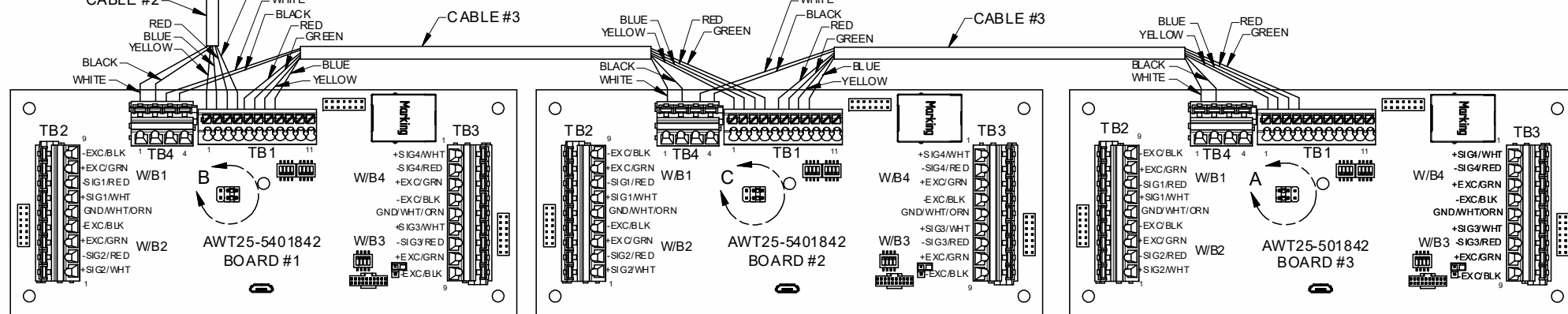

DETAIL B

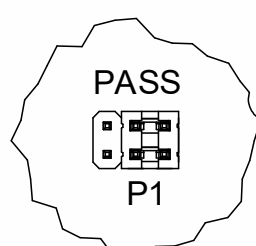

DETAIL C

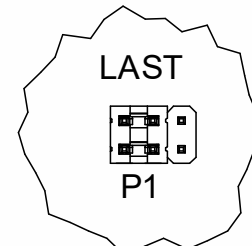

DETAIL A

## 7.4 Wiring for four ZB210 (SG or LG) J-Boxes

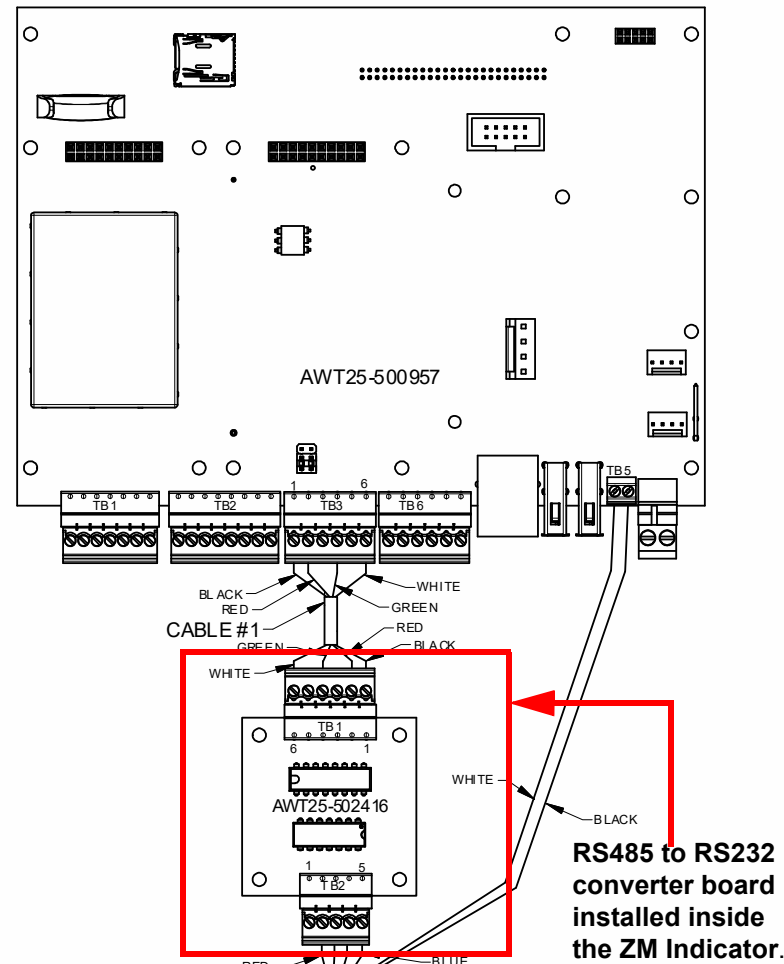

	Start				Wire		End			
	Board	Desc.	TB	Signal	Cable	Color	Board	Desc.	TB	Signal
Cable #1	AWT25-500957	ZM5/6 Main Board	TB3-1	GND (0V)	JUMPER WIRE *	BLACK	AWT25-502416	RS232-to-RS485 Board	TB1-1	GND (0V)
	AWT25-500957	ZM5/6 Main Board	TB3-2	TX1	JUMPER WIRE *	RED	AWT25-502416	RS232-to-RS485 Board	TB1-2	RX1
	AWT25-500957	ZM5/6 Main Board	TB3-4	RX1	JUMPER WIRE *	GREEN	AWT25-502416	RS232-to-RS485 Board	TB1-4	TX1
	AWT25-500957	ZM5/6 Main Board	TB3-6	+5V	JUMPER WIRE *	WHITE	AWT25-502416	RS232-to-RS485 Board	TB1-6	+5V
Cable #2	AWT25-502416	RS232-to-RS485 Board	TB2-2	XMTA	50473-0128	RED	AWT25-501842	ZB210 Main Board #1	TB1-3	RCVA
	AWT25-502416	RS232-to-RS485 Board	TB2-3	XMTB	50473-0128	GREEN	AWT25-501842	ZB210 Main Board #1	TB1-4	RCVB
	AWT25-502416	RS232-to-RS485 Board	TB2-4	RCVA	50473-0128	YELLOW	AWT25-501842	ZB210 Main Board #1	TB1-1	XMTA
	AWT25-502416	RS232-to-RS485 Board	TB2-5	RCVB	50473-0128	BLUE	AWT25-501842	ZB210 Main Board #1	TB1-2	XTMB
	AWT25-500957	ZM5/6 Main Board	TB5-1	+24V	50473-0128	WHITE	AWT25-501842	ZB210 Main Board #1	TB4-1	+24V
	AWT25-500957	ZM5/6 Main Board	TB5-2	GND (0V)	50473-0128	BLACK	AWT25-501842	ZB210 Main Board #1	TB4-2	GND (0V)
Cable #3	AWT25-501842	ZB210 Main Board #1	TB1-5	XMTA2	50473-0094	RED	AWT25-501842	ZB210 Main Board #2	TB1-3	RCVA
	AWT25-501842	ZB210 Main Board #1	TB1-6	XMTB2	50473-0094	GREEN	AWT25-501842	ZB210 Main Board #2	TB1-4	RCVB
	AWT25-501842	ZB210 Main Board #1	TB1-7	RCVA2	50473-0094	YELLOW	AWT25-501842	ZB210 Main Board #2	TB1-1	XMTA
	AWT25-501842	ZB210 Main Board #1	TB1-8	RCVB2	50473-0094	BLUE	AWT25-501842	ZB210 Main Board #2	TB1-2	XTMB
	AWT25-501842	ZB210 Main Board #1	TB4-3	+24V	50473-0094	WHITE	AWT25-501842	ZB210 Main Board #2	TB4-1	+24V
	AWT25-501842	ZB210 Main Board #1	TB4-4	GND (0V)	50473-0094	BLACK	AWT25-501842	ZB210 Main Board #2	TB4-2	GND (0V)

\* CUT JUMPER WIRE FROM 50473-0128 CABLE

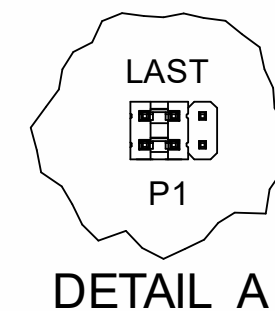
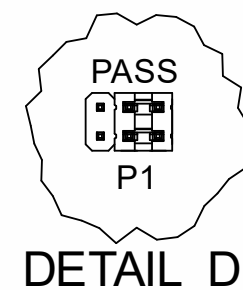
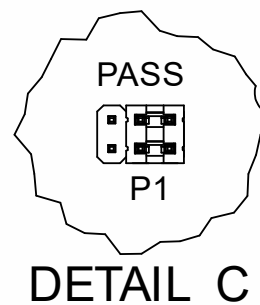
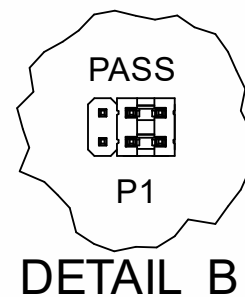
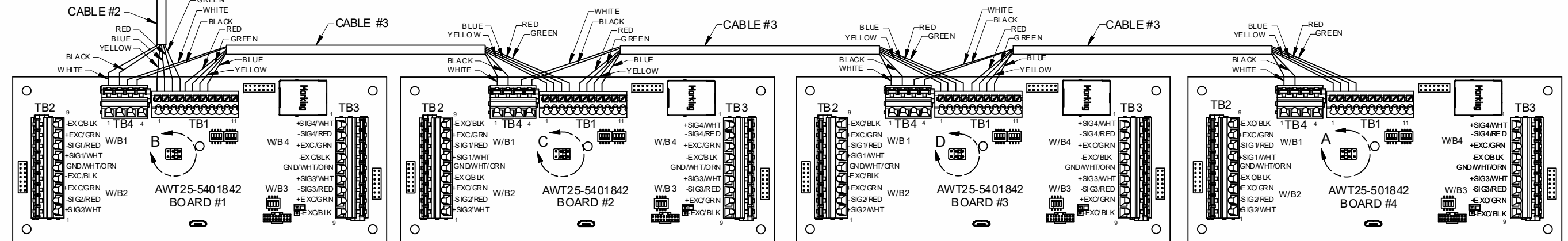

ZB210.cdr



## 7.5 Wiring for single ZB210 (STVS) J-Box

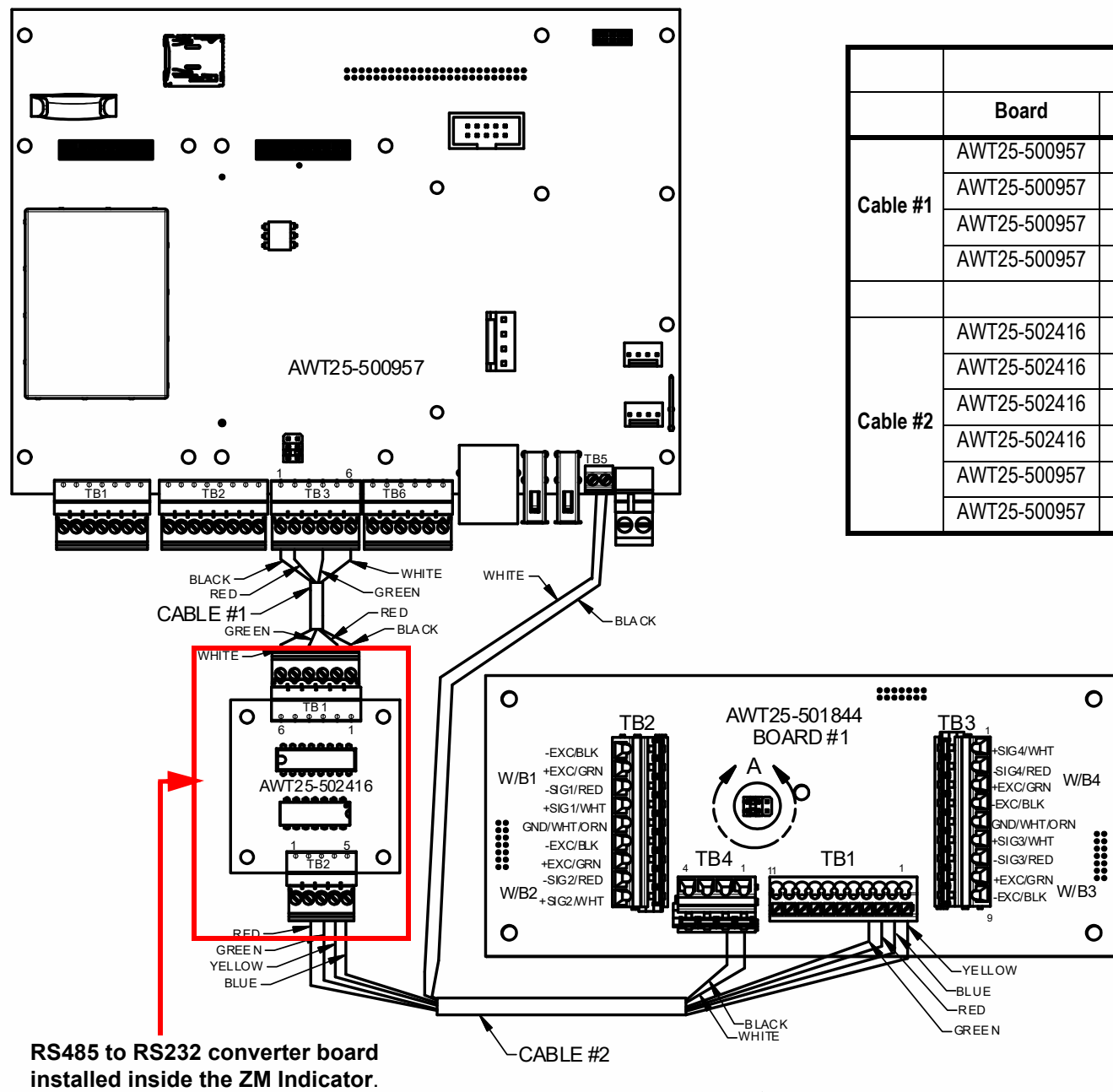

	Start				Wire		End			
	Board	Desc.	TB	Signal	Cable	Color	Board	Desc.	TB	Signal
Cable #1	AWT25-500957	ZM5/6 Main Board	TB3-1	GND (0V)	JUMPER WIRE *	BLACK	AWT25-502416	RS232-to-RS485 Board	TB1-1	GND (0V)
	AWT25-500957	ZM5/6 Main Board	TB3-2	TX1	JUMPER WIRE *	RED	AWT25-502416	RS232-to-RS485 Board	TB1-2	RX1
	AWT25-500957	ZM5/6 Main Board	TB3-4	RX1	JUMPER WIRE *	GREEN	AWT25-502416	RS232-to-RS485 Board	TB1-4	TX1
	AWT25-500957	ZM5/6 Main Board	TB3-6	+5V	JUMPER WIRE *	WHITE	AWT25-502416	RS232-to-RS485 Board	TB1-6	+5V
Cable #2	AWT25-502416	RS232-to-RS485 Board	TB2-2	XMTA	50473-0128	RED	AWT25-501844	ZB210 STVS Board #1	TB1-3	RCVA
	AWT25-502416	RS232-to-RS485 Board	TB2-3	XMTB	50473-0128	GREEN	AWT25-501844	ZB210 STVS Board #1	TB1-4	RCVB
	AWT25-502416	RS232-to-RS485 Board	TB2-4	RCVA	50473-0128	YELLOW	AWT25-501844	ZB210 STVS Board #1	TB1-1	XMTA
	AWT25-502416	RS232-to-RS485 Board	TB2-5	RCVB	50473-0128	BLUE	AWT25-501844	ZB210 STVS Board #1	TB1-2	XTMB
	AWT25-500957	ZM5/6 Main Board	TB5-1	+24V	50473-0128	WHITE	AWT25-501844	ZB210 STVS Board #1	TB4-1	+24V
	AWT25-500957	ZM5/6 Main Board	TB5-2	GND (0V)	50473-0128	BLACK	AWT25-501844	ZB210 STVS Board #1	TB4-2	GND (0V)

\* CUT JUMPER WIRE FROM 50473-0128 CABLE

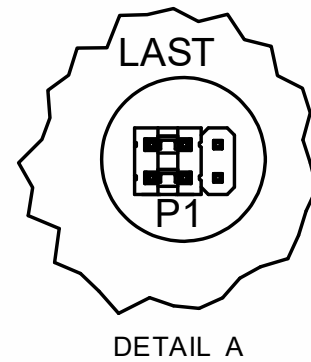

## 7.6 Wiring for two ZB210 (STVS) J-Boxes

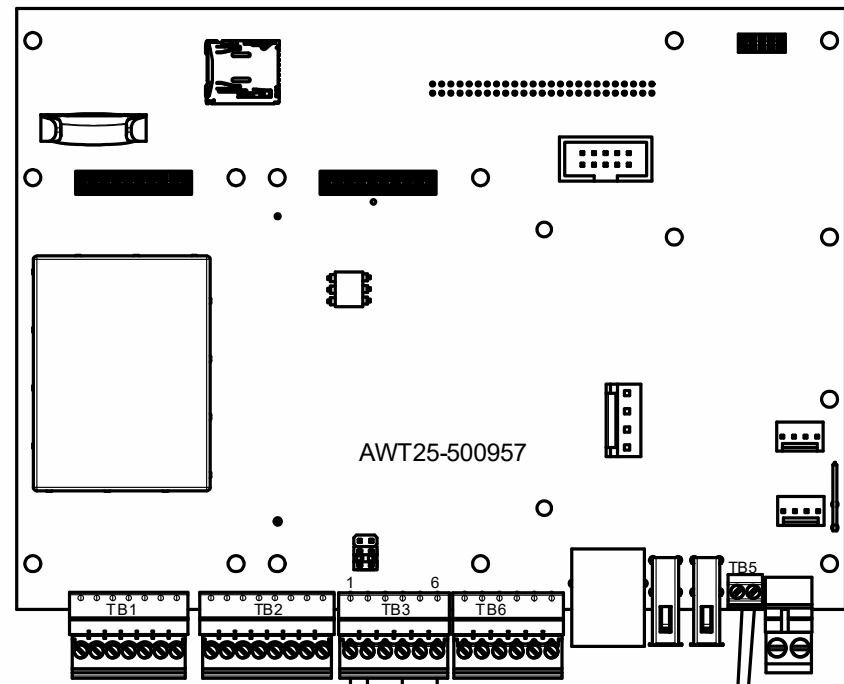

	Start				Wire		End			
	Board	Desc.	TB	Signal	Cable	Color	Board	Desc.	TB	Signal
Cable #1	AWT25-500957	ZM5/6 Main Board	TB3-1	GND (0V)	JUMPER WIRE *	BLACK	AWT25-502416	RS232-to-RS485 Board	TB1-1	GND (0V)
	AWT25-500957	ZM5/6 Main Board	TB3-2	TX1	JUMPER WIRE *	RED	AWT25-502416	RS232-to-RS485 Board	TB1-2	RX1
	AWT25-500957	ZM5/6 Main Board	TB3-4	RX1	JUMPER WIRE *	GREEN	AWT25-502416	RS232-to-RS485 Board	TB1-4	TX1
	AWT25-500957	ZM5/6 Main Board	TB3-6	+5V	JUMPER WIRE *	WHITE	AWT25-502416	RS232-to-RS485 Board	TB1-6	+5V
Cable #2	AWT25-502416	RS232-to-RS485 Board	TB2-2	XMTA	50473-0128	RED	AWT25-501844	ZB210 STVS Board #1	TB1-3	RCVA
	AWT25-502416	RS232-to-RS485 Board	TB2-3	XMTB	50473-0128	GREEN	AWT25-501844	ZB210 STVS Board #1	TB1-4	RCVB
	AWT25-502416	RS232-to-RS485 Board	TB2-4	RCVA	50473-0128	YELLOW	AWT25-501844	ZB210 STVS Board #1	TB1-1	XMTA
	AWT25-502416	RS232-to-RS485 Board	TB2-5	RCVB	50473-0128	BLUE	AWT25-501844	ZB210 STVS Board #1	TB1-2	XTMB
	AWT25-500957	ZM5/6 Main Board	TB5-1	+24V	50473-0128	WHITE	AWT25-501844	ZB210 STVS Board #1	TB4-1	+24V
	AWT25-500957	ZM5/6 Main Board	TB5-2	GND (0V)	50473-0128	BLACK	AWT25-501844	ZB210 STVS Board #1	TB4-2	GND (0V)
Cable #3	AWT25-501844	ZB210 STVS Board #1	TB1-5	XMTA2	50473-0094	RED	AWT25-501844	ZB210 STVS Board #2	TB1-3	RCVA
	AWT25-501844	ZB210 STVS Board #1	TB1-6	XMTB2	50473-0094	GREEN	AWT25-501844	ZB210 STVS Board #2	TB1-4	RCVB
	AWT25-501844	ZB210 STVS Board #1	TB1-7	RCVA2	50473-0094	YELLOW	AWT25-501844	ZB210 STVS Board #2	TB1-1	XMTA
	AWT25-501844	ZB210 STVS Board #1	TB1-8	RCVB2	50473-0094	BLUE	AWT25-501844	ZB210 STVS Board #2	TB1-2	XTMB
	AWT25-501844	ZB210 STVS Board #1	TB4-3	+24V	50473-0094	WHITE	AWT25-501844	ZB210 STVS Board #2	TB4-1	+24V
	AWT25-501844	ZB210 STVS Board #1	TB4-4	GND (0V)	50473-0094	BLACK	AWT25-501844	ZB210 STVS Board #2	TB4-2	GND (0V)

\* CUT JUMPER WIRE FROM 50473-0128 CABLE

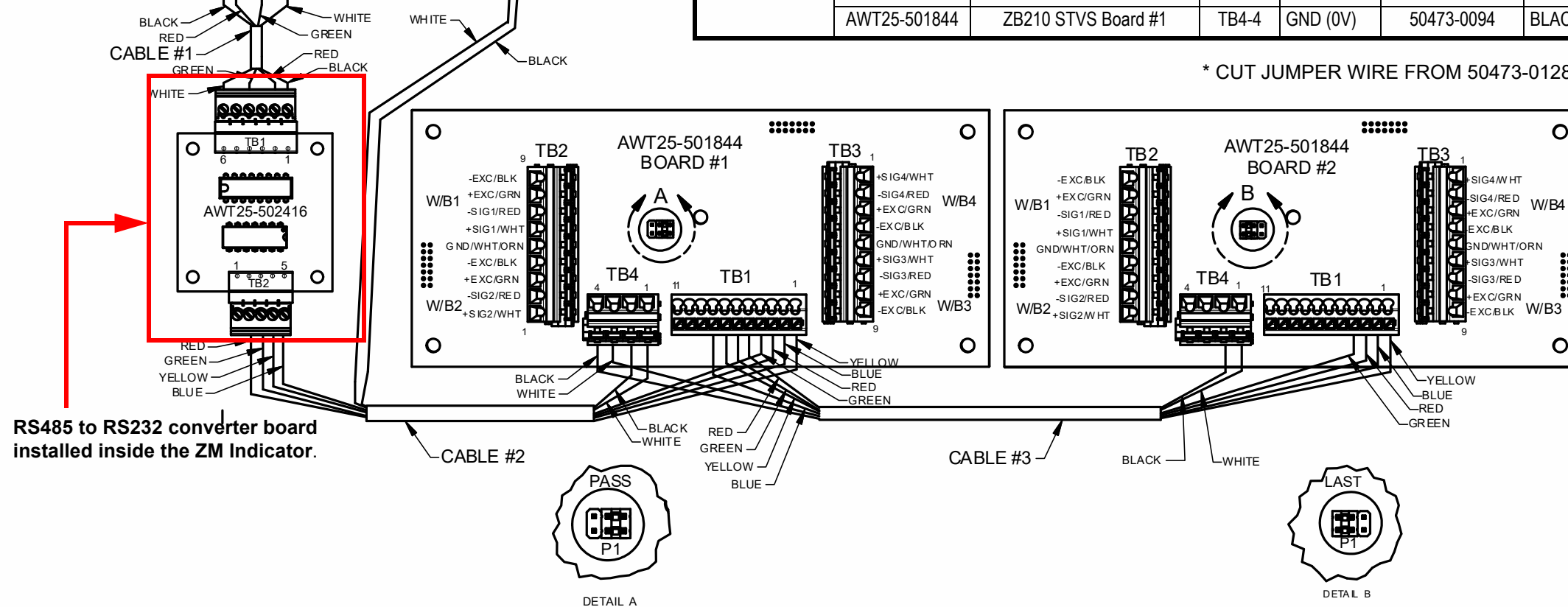

## 7.7 Wiring for three ZB210 (STVS) J-Boxes

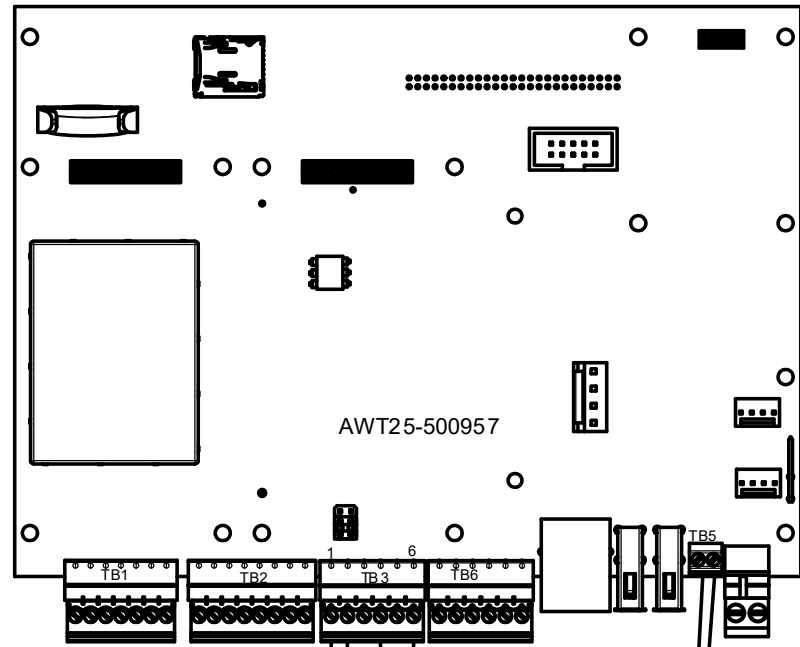

	Start				Wire		End			
	Board	Desc.	TB	Signal	Cable	Color	Board	Desc.	TB	Signal
Cable #1	AWT25-500957	ZM5/6 Main Board	TB3-1	GND (0V)	JUMPER WIRE *	BLACK	AWT25-502416	RS232-to-RS485 Board	TB1-1	GND (0V)
	AWT25-500957	ZM5/6 Main Board	TB3-2	TX1	JUMPER WIRE *	RED	AWT25-502416	RS232-to-RS485 Board	TB1-2	RX1
	AWT25-500957	ZM5/6 Main Board	TB3-4	RX1	JUMPER WIRE *	GREEN	AWT25-502416	RS232-to-RS485 Board	TB1-4	TX1
	AWT25-500957	ZM5/6 Main Board	TB3-6	+5V	JUMPER WIRE *	WHITE	AWT25-502416	RS232-to-RS485 Board	TB1-6	+5V
Cable #2	AWT25-502416	RS232-to-RS485 Board	TB2-2	XMTA	50473-0128	RED	AWT25-501844	ZB210 STVS Board #1	TB1-3	RCVA
	AWT25-502416	RS232-to-RS485 Board	TB2-3	XMTB	50473-0128	GREEN	AWT25-501844	ZB210 STVS Board #1	TB1-4	RCVB
	AWT25-502416	RS232-to-RS485 Board	TB2-4	RCVA	50473-0128	YELLOW	AWT25-501844	ZB210 STVS Board #1	TB1-1	XMTA
	AWT25-502416	RS232-to-RS485 Board	TB2-5	RCVB	50473-0128	BLUE	AWT25-501844	ZB210 STVS Board #1	TB1-2	XTMB
	AWT25-500957	ZM5/6 Main Board	TB5-1	+24V	50473-0128	WHITE	AWT25-501844	ZB210 STVS Board #1	TB4-1	+24V
	AWT25-500957	ZM5/6 Main Board	TB5-2	GND (0V)	50473-0128	BLACK	AWT25-501844	ZB210 STVS Board #1	TB4-2	GND (0V)
Cable #3	AWT25-501844	ZB210 STVS Board #1	TB1-5	XMTA2	50473-0094	RED	AWT25-501844	ZB210 STVS Board #2	TB1-3	RCVA
	AWT25-501844	ZB210 STVS Board #1	TB1-6	XMTB2	50473-0094	GREEN	AWT25-501844	ZB210 STVS Board #2	TB1-4	RCVB
	AWT25-501844	ZB210 STVS Board #1	TB1-7	RCVA2	50473-0094	YELLOW	AWT25-501844	ZB210 STVS Board #2	TB1-1	XMTA
	AWT25-501844	ZB210 STVS Board #1	TB1-8	RCVB2	50473-0094	BLUE	AWT25-501844	ZB210 STVS Board #2	TB1-2	XTMB
	AWT25-501844	ZB210 STVS Board #1	TB4-3	+24V	50473-0094	WHITE	AWT25-501844	ZB210 STVS Board #2	TB4-1	+24V
	AWT25-501844	ZB210 STVS Board #1	TB4-4	GND (0V)	50473-0094	BLACK	AWT25-501844	ZB210 STVS Board #2	TB4-2	GND (0V)

\* CUT JUMPER WIRE FROM 50473-0128 CABLE

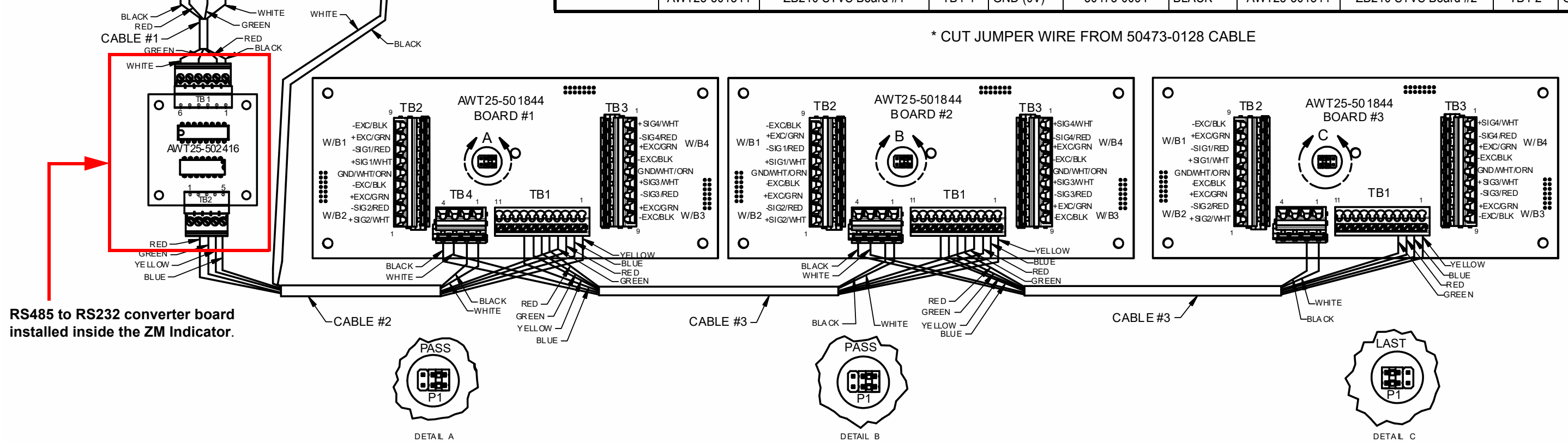

RS485 to RS232 converter board installed inside the ZM Indicator.

## 7.8 Wiring for four ZB210 (STVS) J-Boxes

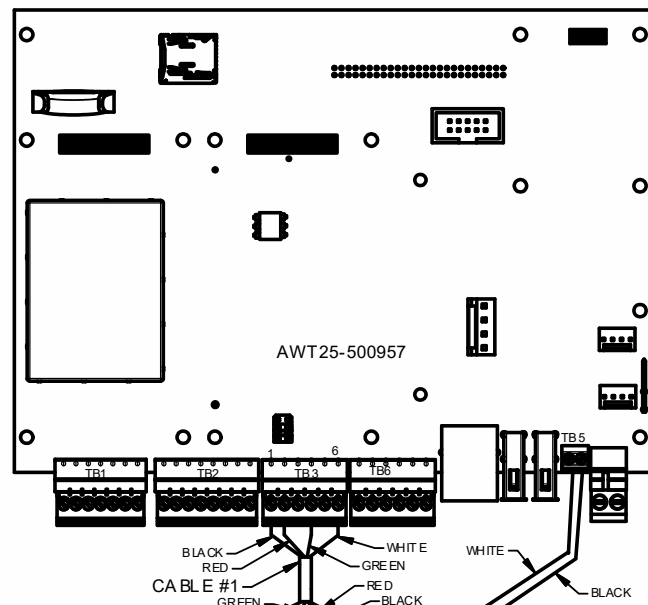

	Start				Wire		End			
	Board	Desc.	TB	Signal	Cable	Color	Board	Desc.	TB	Signal
Cable #1	AWT25-500957	ZM5/6 Main Board	TB3-1	GND (0V)	JUMPER WIRE *	BLACK	AWT25-502416	RS232-to-RS485 Board	TB1-1	GND (0V)
	AWT25-500957	ZM5/6 Main Board	TB3-2	TX1	JUMPER WIRE *	RED	AWT25-502416	RS232-to-RS485 Board	TB1-2	RX1
	AWT25-500957	ZM5/6 Main Board	TB3-4	RX1	JUMPER WIRE *	GREEN	AWT25-502416	RS232-to-RS485 Board	TB1-4	TX1
	AWT25-500957	ZM5/6 Main Board	TB3-6	+5V	JUMPER WIRE *	WHITE	AWT25-502416	RS232-to-RS485 Board	TB1-6	+5V
Cable #2	AWT25-502416	RS232-to-RS485 Board	TB2-2	XMTA	50473-0128	RED	AWT25-501844	ZB210 STVS Board #1	TB1-3	RCVA
	AWT25-502416	RS232-to-RS485 Board	TB2-3	XMTB	50473-0128	GREEN	AWT25-501844	ZB210 STVS Board #1	TB1-4	RCVB
	AWT25-502416	RS232-to-RS485 Board	TB2-4	RCVA	50473-0128	YELLOW	AWT25-501844	ZB210 STVS Board #1	TB1-1	XMTA
	AWT25-502416	RS232-to-RS485 Board	TB2-5	RCVB	50473-0128	BLUE	AWT25-501844	ZB210 STVS Board #1	TB1-2	XTMB
	AWT25-500957	ZM5/6 Main Board	TB5-1	+24V	50473-0128	WHITE	AWT25-501844	ZB210 STVS Board #1	TB4-1	+24V
	AWT25-500957	ZM5/6 Main Board	TB5-2	GND (0V)	50473-0128	BLACK	AWT25-501844	ZB210 STVS Board #1	TB4-2	GND (0V)
Cable #3	AWT25-501844	ZB210 STVS Board #1	TB1-5	XMTA2	50473-0094	RED	AWT25-501844	ZB210 STVS Board #2	TB1-3	RCVA
	AWT25-501844	ZB210 STVS Board #1	TB1-6	XMTB2	50473-0094	GREEN	AWT25-501844	ZB210 STVS Board #2	TB1-4	RCVB
	AWT25-501844	ZB210 STVS Board #1	TB1-7	RCVA2	50473-0094	YELLOW	AWT25-501844	ZB210 STVS Board #2	TB1-1	XMTA
	AWT25-501844	ZB210 STVS Board #1	TB1-8	RCVB2	50473-0094	BLUE	AWT25-501844	ZB210 STVS Board #2	TB1-2	XTMB
	AWT25-501844	ZB210 STVS Board #1	TB4-3	+24V	50473-0094	WHITE	AWT25-501844	ZB210 STVS Board #2	TB4-1	+24V
	AWT25-501844	ZB210 STVS Board #1	TB4-4	GND (0V)	50473-0094	BLACK	AWT25-501844	ZB210 STVS Board #2	TB4-2	GND (0V)

\* CUT JUMPER WIRE FROM 50473-0128 CABLE

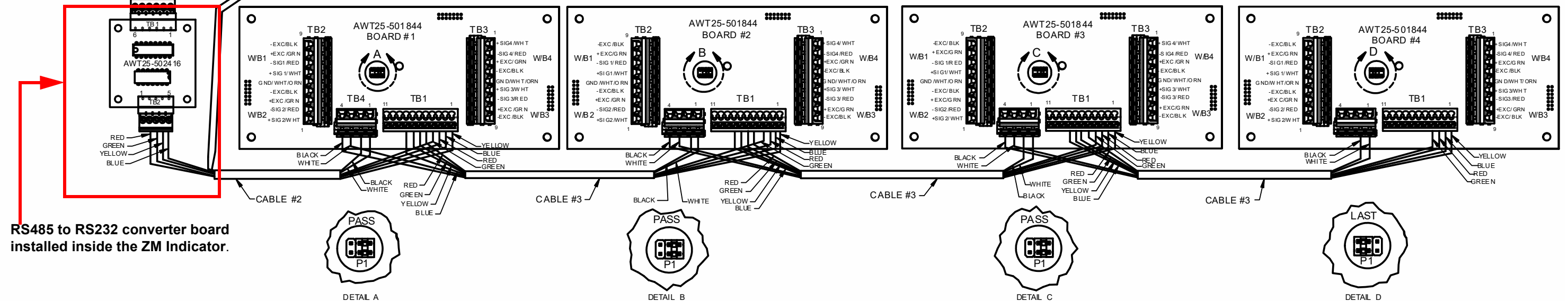

RS485 to RS232 converter board installed inside the ZM Indicator.

## 7.9 Wiring for RS232

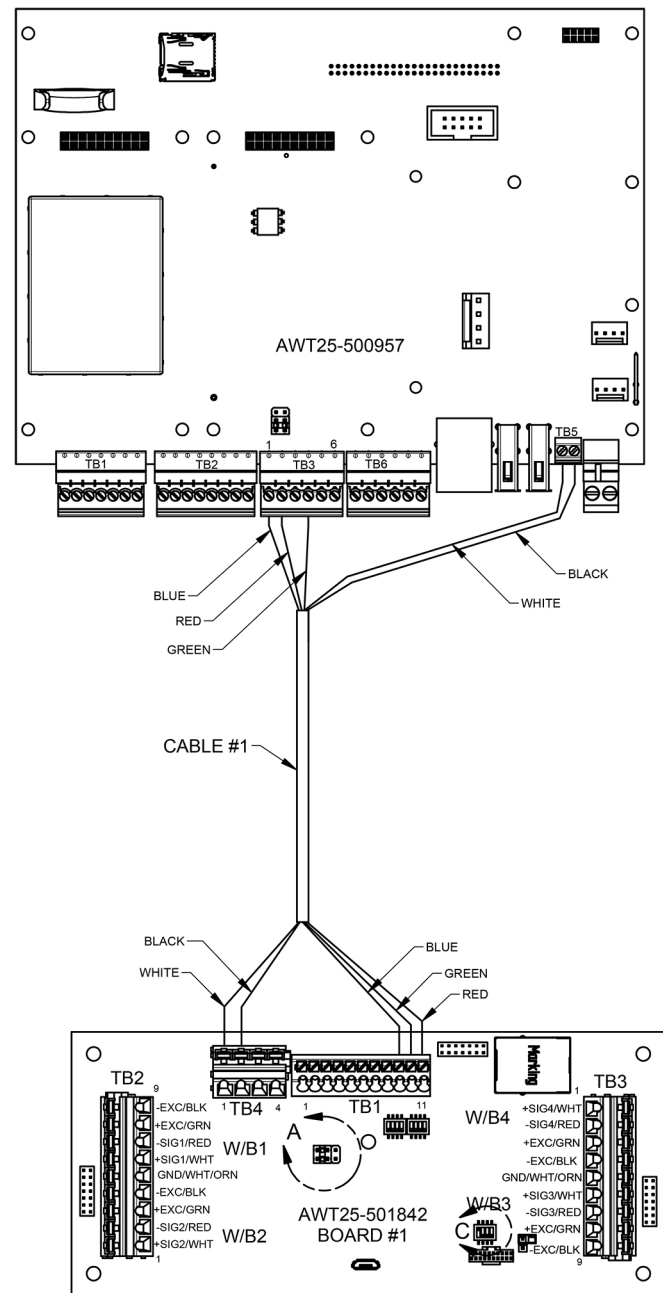

	Start				Wire		End			
	Board	Desc.	TB	Signal	Cable	Color	Board	Desc.	TB	Signal
Cable #1	AWT25-500957	ZM5/6 Main Board	TB3-1	GND (0V)	50473-0128	BLUE	AWT25-501842	ZB210 Main Board #1	TB1-9	GND (0V)
	AWT25-500957	ZM5/6 Main Board	TB3-2	TX1	50473-0128	RED	AWT25-501842	ZB210 Main Board #1	TB1-11	RX1
	AWT25-500957	ZM5/6 Main Board	TB3-4	RX1	50473-0128	GREEN	AWT25-501842	ZB210 Main Board #1	TB1-10	TX1
	AWT25-500957	ZM5/6 Main Board	TB5-1	+24V	50473-0128	WHITE	AWT25-501842	ZB210 Main Board #1	TB4-1	+24V
AWT25-500957	ZM5/6 Main Board	TB5-2	GND (0V)	50473-0128	BLACK	AWT25-501842	ZB210 Main Board #1	TB4-2	GND (0V)	

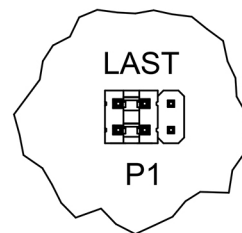

DETAIL A

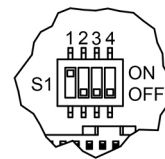

DETAIL C





## **Avery Weigh-Tronix**

---

### **Avery Weigh-Tronix USA**

1000 Armstrong Dr.  
Fairmont MN 56031 USA  
Tel:507-238-4461  
Fax:507-238-4195  
Email: [usinfo@awtxglobal.com](mailto:usinfo@awtxglobal.com)  
[www.averyweigh-tronix.com](http://www.averyweigh-tronix.com)

### **Avery Weigh-Tronix UK**

Foundry Lane,  
Smethwick, West Midlands,  
England B66 2LP  
Tel:+44 (0) 8453 66 77 88  
Fax:+44 (0)121 224 8183  
Email: [info@awtxglobal.com](mailto:info@awtxglobal.com)  
[www.averyweigh-tronix.com](http://www.averyweigh-tronix.com)