

Avery Weigh-Tronix

Weighline and Model E1310 Indicator

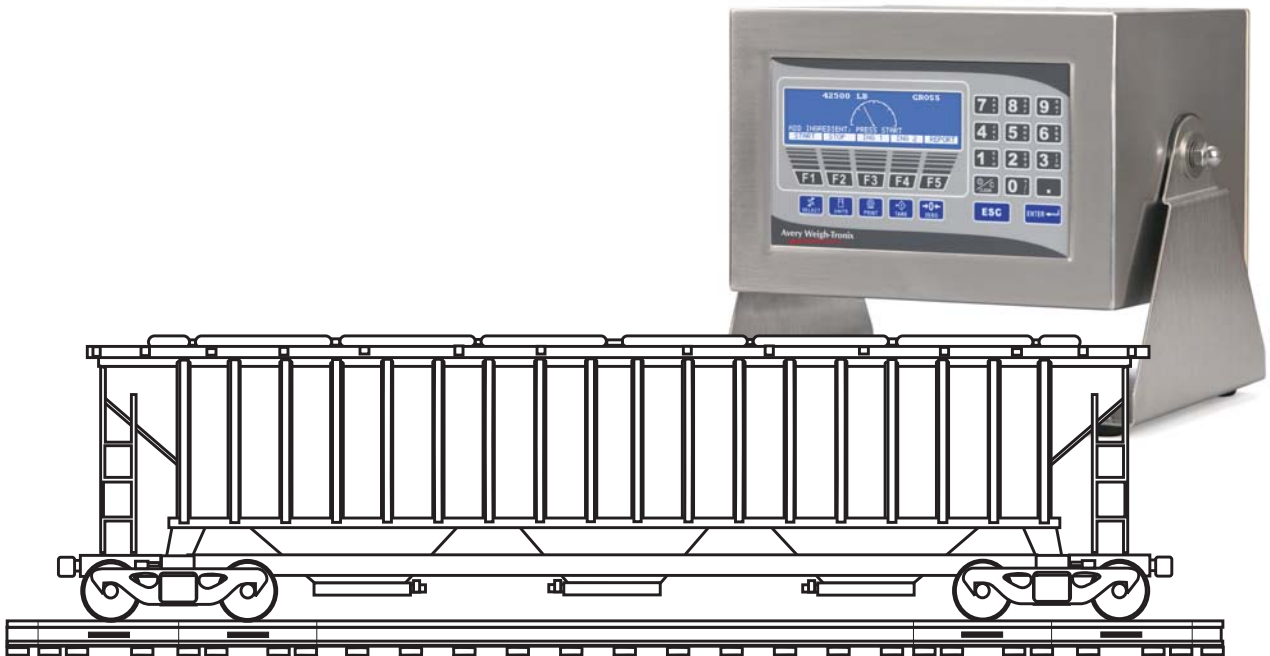

Weighline & E1310

User Instructions

ENGLISH - USA

AWT35-500115 Issue A February 20, 2007



Table of Contents

	<i>page</i>
Table of Contents	3
Weighline Application	4
Introduction	4
Weighing Operations	5
Multi-scale, Full Draft Weighing	7
Multi-scale, Dual Draft Weighing Sequence	8
Single Scale, Dual Draft Weighing	11
Password Protected Menus	13
SCALES Softkey	13
ID_TYPE Softkey	13
SET_PT Softkey	13
EXIT Softkey	13
Serial Data Transfers	14
Sample Tickets	14
Serial Communication	14
Serial Port Defaults	15

Weighline Application

1

1.1 Introduction

These instructions cover the operation of the Weighline scale and the Model E1310 indicator with the Weighline application installed.

There is a multi-scale mode and a single scale mode. The mode is setup in a password protected menu covered in a later section of the manual. The modes are explained below:

Multi-scale mode When you have two connected Weighline scales, as shown in Figure 1.1, you can use multi-scale mode.

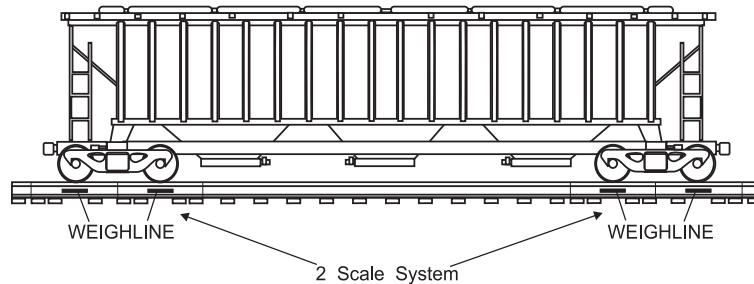

Figure 1.1 Multi-scale system, full draft example

Full and Dual draft weighing are both possible in multi-scale mode.

Full draft Full draft weighing is when a rail car's trucks are spaced so that both are centered over the Weighline scales at the same time. This situation is illustrated in Figure 1.1.

Dual draft Dual draft weighing is when the spacing of the trucks does not match the spacing of the scales. See Figure 1.2. This means the two trucks must be weighed at separate times. The two readings can be taken on one of the scales or one reading on each scale.

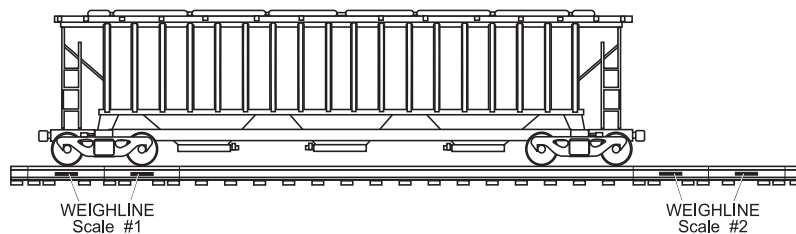

Figure 1.2 Multi-scale, dual draft example

Single scale mode

In single scale mode there is one Weighline scale and only dual draft weighing is available.

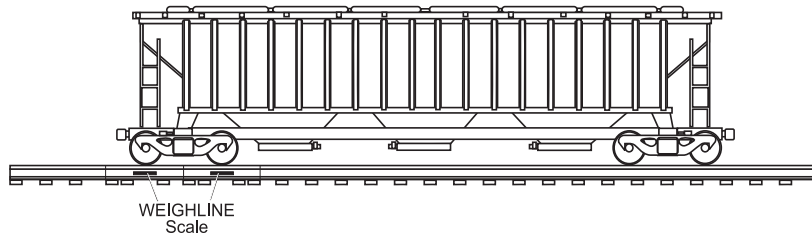

Figure 1.3 Single scale, dual draft example

The weighing procedures for each of the modes is provided in the following pages.

1.2 Weighing Operations



Please remember ...

To calibrate the Weighline scale, consult the Calibration section of the E1310 Service Manual.

There are preliminary steps to the weighing operations. They are:

Zeroing the scale platform on page 5

Tare entry on page 5

Car ID entry on page 6

When you are done with these you can skip to the following procedure for your weighing situation:

Multi-scale, Full Draft Weighing on page 7

Multi-scale, Dual Draft Weighing Sequence on page 8

Single Scale, Dual Draft Weighing on page 11

Zeroing the scale platform

Press the **ZERO** key to zero the scale. This is necessary only if the scale is more than ± 3 scale divisions from zero weight.

Tare entry

Press the **TARE** key and the display prompts the operator to enter a 6-digit numeric value to identify the empty car weight being used in the current weighing process.

ENTER TOTAL CAR TARE 120500_

BKSP←

-NEG

Key in total weight of an empty rail car to be used for Gross-Tare-Net calculations and press the **ENTER** key.

Car ID entry

Follow these steps to enter the car ID (up to 14 characters).

1. Press the **ID** softkey...

Based on indicator configuration, you can enter a purely numeric or an alphanumeric ID.

If your indicator is set up for alphanumeric entry, when you press a key repeatedly the display will show the number then the letters associated with the key. You can also use the softkeys to scroll through a complete alpha and numeric character set to enter your ID. See Figure 1.4. When you're done, press the **ENTER** key.

If your indicator is set up for numeric entry, press the correct numeric keys for your rail car ID and press the **ENTER** key. See Figure 1.5

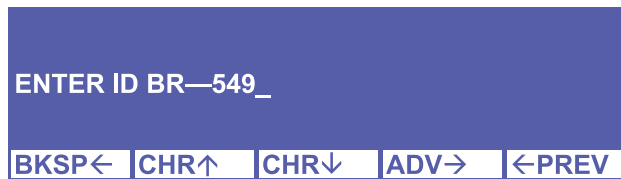

Figure 1.4 Alphanumeric entry sample



Figure 1.5 Numeric entry sample



Please remember ...

How your screen appears depends on the setup of your indicator. See Password Protected Menus on page 13 to change the setup.

1.3 Multi-scale, Full Draft Weighing



Please remember ...

Zeroing the scale, Tare entry and ID entry are functional in both dual draft and full draft weighing. Also, Full draft weighing requires the connection of 2-scales and indicator configuration for multi-scale.

If your system is set up for multi-scale, full draft weighing follow these steps:

1. Upon power up your screen will resemble this example:

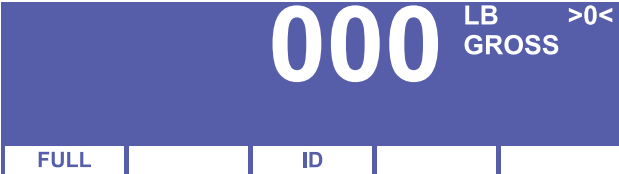

2. Place the rail car correctly on both scales, as shown below:

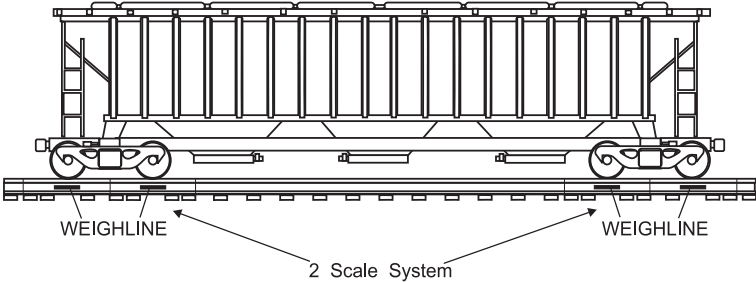

The total car weight is displayed, as shown below:

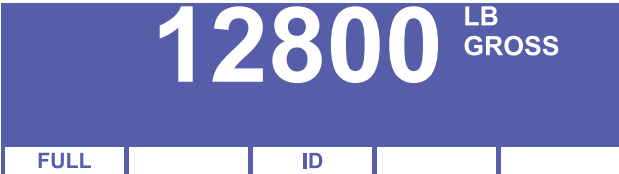

3. Remove the car and repeat steps 2 and 3 for the next car.

1.4 Multi-scale, Dual Draft Weighing Sequence

To change modes from Full to Dual, press the **F1** softkey. The display changes to one similar to this example:

000	G	LB	END	1
000	G	LB	END	2
000	G	LB	TOTAL	3
DUAL	1ST	ID		SCALE 1

You will use the **SCALE 1** or **SCALE 2** softkeys to weigh short cars or long cars. See the illustrations below then follow the steps starting at Step 1 below.

Short cars:

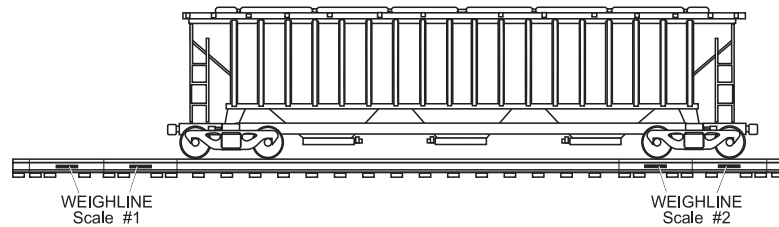
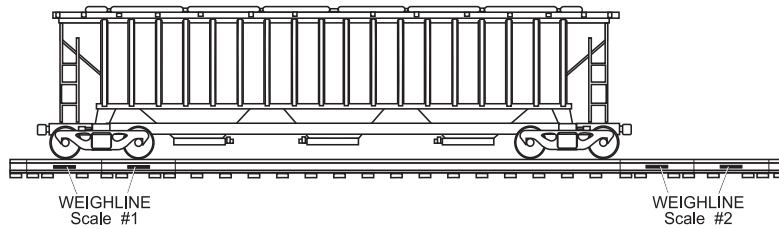

Long Cars:

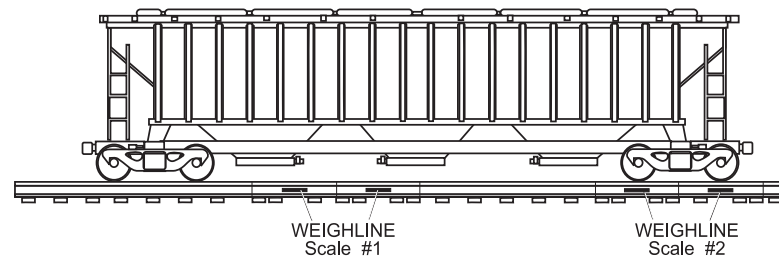
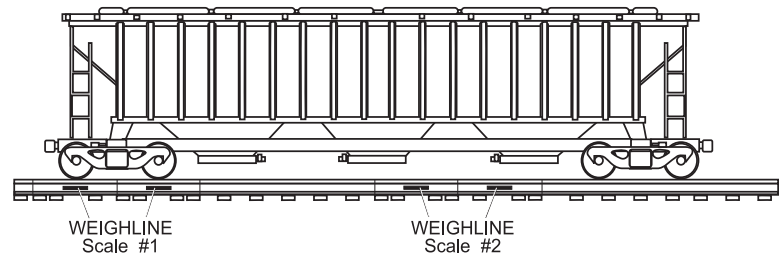

1. With the scale empty move the first truck, or end, of the rail car to be weighed on to the scale platform. Position the rail car on the scale as shown below.

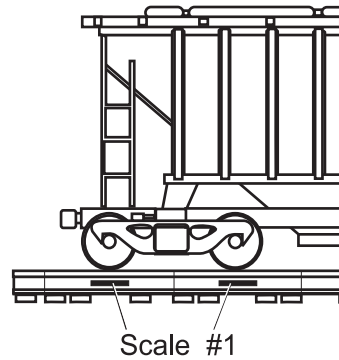

Figure 1.6 First truck positioned over Scale #1

An example display is shown below.

124000 G LB END 1				
000 G LB END 2				
124000 G LB TOTAL 3				
DUAL	1ST	ID		SCALE 1

The top line, **End 1**, shows the live weight on the scale. The third line, **TOTAL 3**, shows the total weight on both scales.

2. When the weight is stable, press the **1ST** softkey...

The live weight of the first end of the rail car is captured. The following is displayed.

124000 G LB END 1				
124000 G LB END 2				
248000 G LB TOTAL 3				
DUAL			2ND	SCALE 1

The top line, **End 1**, shows the captured weight of End 1. The middle line, **End 2**, shows the live weight on scale #1.

3. Press the **Scale 1** softkey to switch the 2nd display line to show Scale 2 weight.

124000 G LB END 1				
000 G LB END 2				
124000 G LB TOTAL 3				
DUAL			2ND	SCALE 2

- Position the second end of the same rail car over Scale #2, as shown below:

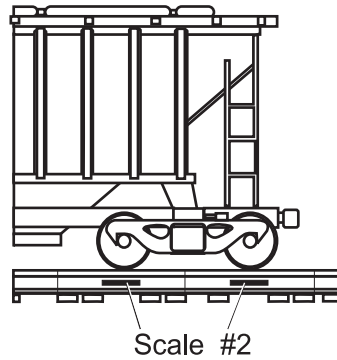

124000	G	LB	END 1
119000	G	LB	END 2
243000	G	LB	TOTAL 3
DUAL			2ND SCALE 2

The top line, **End 1**, shows the captured weight of End 1. The middle line, **END 2**, shows the live weight on scale #2. The third line shows the total of the rail car.

- Press the **2ND** softkey when the car weight is stable. This will capture the weight of the second end of the rail car. The display advances to the next screen.

124000	G	LB	END 1
119000	G	LB	END 2
243000	G	LB	TOTAL 3
		NEXT	

The rail car can be removed from the scale.

- Press the **PRINT** key to print the rail car information: Time, Date, and ID if entered, Gross, Tare, and Net. (See *Sample Tickets on page 14*) The total rail car weights will remain on the display until the **NEXT** softkey has been pressed.
- Press the **NEXT** softkey to process the next rail car the display returns to the main menu.



Please remember ...

If one of the scales is not functioning, you can use the remaining scale to continue weighing rail cars. Follow the steps in Multi-scale, Dual Draft Weighing Sequence on page 8. The displays will be slightly different due to the fact that you are in multi-scale mode. Select only the functioning weighline scale to use for weighing of both rail car ends.

1.5 Single Scale, Dual Draft Weighing

With the indicator setup for single scale mode and no weight on the scale, you will see the following screen:

000				G	LB	END 1
000				G	LB	END 2
000				G	LB	TOTAL 3
DUAL	1ST	ID				

1. Move the first end of the rail car to be weighed onto the scale. Position the rail car on the scale as shown in Figure 1.7.

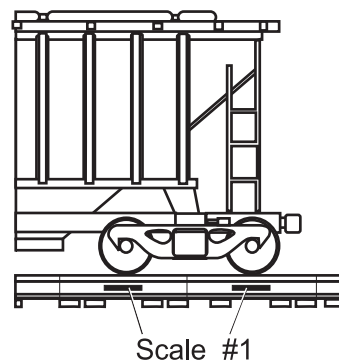

Figure 1.7 First truck positioned over scale

The display shows the 1st end weight on the top line of the display and the total weight on the bottom line. See the example below:

124000				G	LB	END 1
000				G	LB	END 2
124000				G	LB	TOTAL 3
DUAL	1ST	ID				

2. When the weight is stable, press the **1ST** softkey. This will capture the weight of the 1st end of the rail car and the display advances to the next screen.

The top line shows the captured weight and the middle line shows the live weight on the scale.

124000				G	LB	END 1
124000				G	LB	END 2
248000				G	LB	TOTAL 3
DUAL	1ST	ID				

3. Position the second end of the same rail car on the scale platform as shown in Figure 1.8.

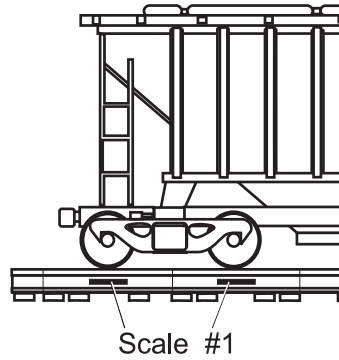

Figure 1.8 Second truck in position over scale

The display, shown below, shows the weight of the 2nd end on the middle line. The bottom line shows the gross weight of the car (end 1 and end 2 added together).

124000	G	LB	END 1
119000	G	LB	END 2
243000	G	LB	TOTAL 3
DUAL			2ND

4. Press the **2ND** softkey when the car weight is stable. This will capture the weight of the second end of the rail car. The display advances to the next screen.

124000	G	LB	END 1
119000	G	LB	END 2
243000	G	LB	TOTAL 3
		NEXT	

5. Remove the rail car from the scale.
6. Press the **PRINT** key to print the rail car information: Time, Date, ID (if entered), Gross, Tare, and Net. (See sample tickets) The total rail car weights will remain on the display until you press the **NEXT** softkey.
7. Press the **NEXT** softkey to process the next rail car...
The display returns to the main menu.

Password Protected Menus

2

Press and hold the **ESC** key (3-5 seconds). At the prompt enter the password “963” and press **ENTER**. New softkeys appear as follows:



The keys are explained below.

2.1 SCALES Softkey

Prompts you

MULTI-SCALE?

YES Sets the system to work with 2-scales connected. Both FULL and DUAL draft modes are available for use.

NO Sets the system to work with only 1-scale connected. Only DUAL draft mode is available for use.

2.2 ID_TYPE Softkey

Prompts you

ALL ID'S ARE NUMERIC ONLY

TOGGLE ID ENTRY TYPE

TOGGLE Sets the ID type to ALPHANUMERIC or NUMERIC depending on the current setting when pressed.

EXIT Returns you to the previous menu.

2.3 SET_PT Softkey

Prompts you

MODIFY SETPOINTS?

YES First prompts you to enter set point 1 value then set point 2 value.

NO Retains the old set point values and returns you to the previous menu.

2.4 EXIT Softkey

Returns you to the previous menu.

Serial Data Transfers

3

3.1 Sample Tickets

With Rail Car ID	Without Rail Car ID
<pre> 05:57 AM 03-10-2007 Car ID: 00000000BR-549 G 241000 LB T 80000 LB N 161000 LB </pre>	<pre> 05:57 AM 03-10-2007 G 241000 LB T 80000 LB N 161000 LB </pre>

3.2 Serial Communication

Serial port # 1 is used for SensorComm.

Serial port # 2 can be used for (1) remote display. (RD4100/6100) or (XR-series). See note below.



Please remember ...

If using 20ma current loop for port 2, select that as your choice with SimPoser before you download or change it via the front panel under the configuration menu level.

The data is sent in the following format:

G 86320 LB

G<sp>#####<sp>UU<cr><lf>

Serial port # 3 can be used for a dot-matrix style of printer (TM-295, WP-23x, etc.)

G 241000 LB

T 80000 LB

N 161000 LB

G<sp>#####<sp>UU<cr><lf>

T<sp>#####<sp>UU<cr><lf>

N<sp>#####<sp>UU<cr><lf>

Serial port # 4 is not used.

3.3 Serial Port Defaults

	Ports 1, 2, 3,4
Baud:	9600
Data Bits:	8
Parity:	None
Stop Bits:	1
EOM:	13
Handshake:	None
Mode:	Basic Control

Avery Weigh-Tronix



Avery Weigh-Tronix USA

1000 Armstrong Dr.
Fairmont MN 56031 USA
Tel: 507-238-4461
Fax: 507-238-4195
Email: industrial@weigh-tronix.com
www.wtxweb.com

Avery Weigh-Tronix UK

Foundry Lane,
Smethwick, West Midlands,
England B66 2LP
Tel: +44 (0)870 903 4343
Fax: +44 (0)121 224 8183
Email: info@awtxglobal.com
www.averyweigh-tronix.com